

---

**US ARMY ENGINEER SCHOOL  
PLUMBING FIXTURES  
(PLUMBING IV)**

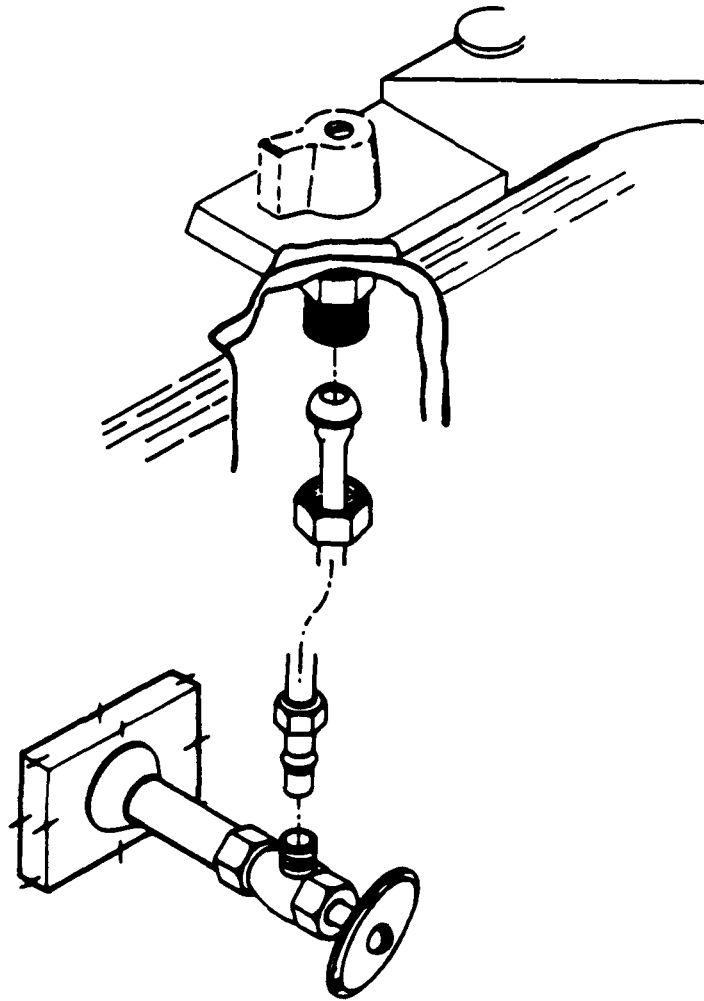

**THE ARMY INSTITUTE FOR PROFESSIONAL DEVELOPMENT  
ARMY CORRESPONDENCE COURSE PROGRAM**

**A  
I  
P  
D**

**READINESS/  
PROFESSIONALISM**



**THRU  
GROWTH**

**US ARMY PLUMBER  
MOS 51K SKILL LEVELS 1 AND 2 COURSE**

**PLUMBING FIXTURES  
(PLUMBING IV)**

**SUBCOURSE NO. EN5113**

**US Army Engineer School  
Fort Leonard Wood, Missouri**

**Twelve Credit Hours**

**GENERAL**

The plumbing fixtures subcourse, part of the Plumber MOS 51K Skill Levels 1 and 2 course, is designed to teach the skills and knowledge necessary for performing tasks related to installing plumbing fixtures such as lavatories and sinks, water closets with tanks, and urinals. The subcourse is presented in three lessons, each corresponding to a terminal objective as indicated below.

**Lesson 1: INSTALLATION OF  
LAVATORIES AND SINKS**

**OBJECTIVE:** Describe the procedures for installing lavatories and sinks.

**TASK:** Task No. 051-248-1008, Install lavatory and sink.

**CONDITIONS:** Given subcourse booklet EN5113 and an examination response sheet. You will work at your own pace and in your own selected environment with no supervision.

**STANDARDS:** Within approximately 4 hours, you should be able to study the lesson resources, answer the review exercises, and select the correct responses to each examination question. You must respond correctly to 70 percent of the examination questions in order to receive credit for the subcourse.

## **Lesson 2: INSTALLATION OF WATER CLOSETS**

**OBJECTIVE:** Describe the procedures for installing water closets with tanks.

**TASK:** Task No. 051-248-1009, Install water closet with tank.

**CONDITIONS:** Given subcourse booklet EN 5113 and an examination response sheet. You will work at your own pace and in your own environment with no supervision.

**STANDARDS:** Within approximately 4 hours, you should be able to study the lesson resources, answer the review exercises, and select the correct response to each examination question. You must respond correctly to 70 percent of the examination questions in order to receive credit for the subcourse.

## **Lesson 3: INSTALLATION OF URINALS**

**OBJECTIVE:** Describe the procedures for installing urinals.

**TASK:** Task No. 051-248-1010, Install urinals.

**CONDITIONS:** Given subcourse booklet EN5113 and an examination response sheet. You will work at your own pace and in your own environment with no supervision.

**STANDARDS:** Within approximately 4 hours, you should be able to study the lesson resources, answer the review exercises, and select the correct response to each examination question. You must respond correctly to 70 percent of the examination questions in order to receive credit for the subcourse.

## TABLE OF CONTENTS

	PAGE
ADMINISTRATIVE INSTRUCTIONS .....	v
GRADING AND CERTIFICATION INSTRUCTIONS .....	v
INTRODUCTION.....	v
<b>Lesson 1: INSTALLATION OF LAVATORIES AND SINKS .....</b>	<b>1</b>
Learning Event 1: Identifying Lavatories and Sinks .....	2
Learning Event 2: Installing Wall-Hung Lavatories .....	5
Learning Event 3: Installing Faucets .....	10
Learning Event 4: Attaching Drain Outlets .....	12
Learning Event 5: Installing P-Traps .....	18
Learning Event 6: Installing Shutoff Angle Valves .....	20
Learning Event 7: Installing Flexible Tubing .....	26
Learning Event 8: Testing for Mechanical Operation and Leaks .....	29
Review Exercise.....	31
Review Exercise Solutions .....	36
<b>Lesson 2: INSTALLATION OF WATER CLOSETS WITH FLUSHING DEVICES.....</b>	<b>37</b>
Learning Event 1: Identifying Water Closets .....	38
Learning Event 2: Installing Water Closets.....	40
Learning Event 3: Attaching Flushing Devices .....	45
Learning Event 4: Installing Flushing Mechanisms.....	50
Learning Event 5: Installing Flushometers.....	56
Learning Event 6: Installing Water Service.....	59
Learning Event 7: Adjusting Flushing Mechanisms .....	61
Learning Event 8: Installing the Seats.....	64
Review Exercise .....	66
Review Exercise Solutions .....	71

<b>Lesson 3: INSTALLATION OF URINALS</b> .....	72
Learning Event 1: Identifying Urinals .....	73
Learning Event 2: Installing Wall-Hung Urinals .....	77
Learning Event 3: Attaching Drain Outlets .....	79
Learning Event 4: Connecting P-Traps to Urinals .....	81
Learning Event 5: Installing Flushometers .....	84
Review Exercise .....	88
Review Exercise Solutions .....	90

**STUDENT INQUIRY SHEET**

(Administrative) ..... Following Examination

**STUDENT INQUIRY SHEET**

(Subcourse Content) ..... Following Examination

---

**\*\*\* IMPORTANT NOTICE\*\*\***

**THE PASSING SCORE FOR ALL ACCP MATERIAL IS NOW 70%.**

**PLEASE DISREGARD ALL REFERENCES TO THE 75% REQUIREMENT.**

---

## **INTRODUCTION**

Plumbing fixtures are receptacles for personal sanitation that discharge waste disposal into the main sanitary waste system of a building. Fixtures are manufactured in vitreous china, enameled cast iron, stainless steel, fiberglass, or plastic. These materials are durable, corrosion-resistant and nonabsorbent. All fixtures come from the manufacturer with rough-in instruction on how to install the item. Fixtures such as lavatories, sinks, water closets, and urinals are installed after the finished building walls and floors are completed. Once installed, all fixtures are tested for mechanical operation and leaks.

**Lesson 1**  
**INSTALLATION OF**  
**LAVATORIES AND SINKS**

**OBJECTIVE**

At the end of this lesson, you will be able to describe the procedures used to install a lavatory and sink.

**TASK**

Task No. 051-248-1008, Install lavatory and sink.

**CONDITIONS**

You will have subcourse booklet EN5113 and an examination response sheet. You will work at your own pace and in your own selected environment with no supervision.

**STANDARDS**

Within approximately 4 hours, you should be able to study the lesson resources, answer the review exercises, and select the correct response to each examination question. You must respond correctly to 70 percent of the examination questions in order to receive credit for this subcourse.

**CREDIT HOURS**

4

**REFERENCES**

FM 5-51K  
TM 5-551K

Lesson 1  
INSTALLATION OF LAVATORIES AND SINKS

Learning Event 1:  
IDENTIFYING LAVATORIES AND SINKS

A lavatory/sink is a fixture that is supplied with both hot and cold water. Its waste disposal drains into the building's waste system. Lavatories/ sinks come in many shapes and sizes. They can be made of vitreous china, enameled cast iron, and stainless steel (see Figures 1 and 2).

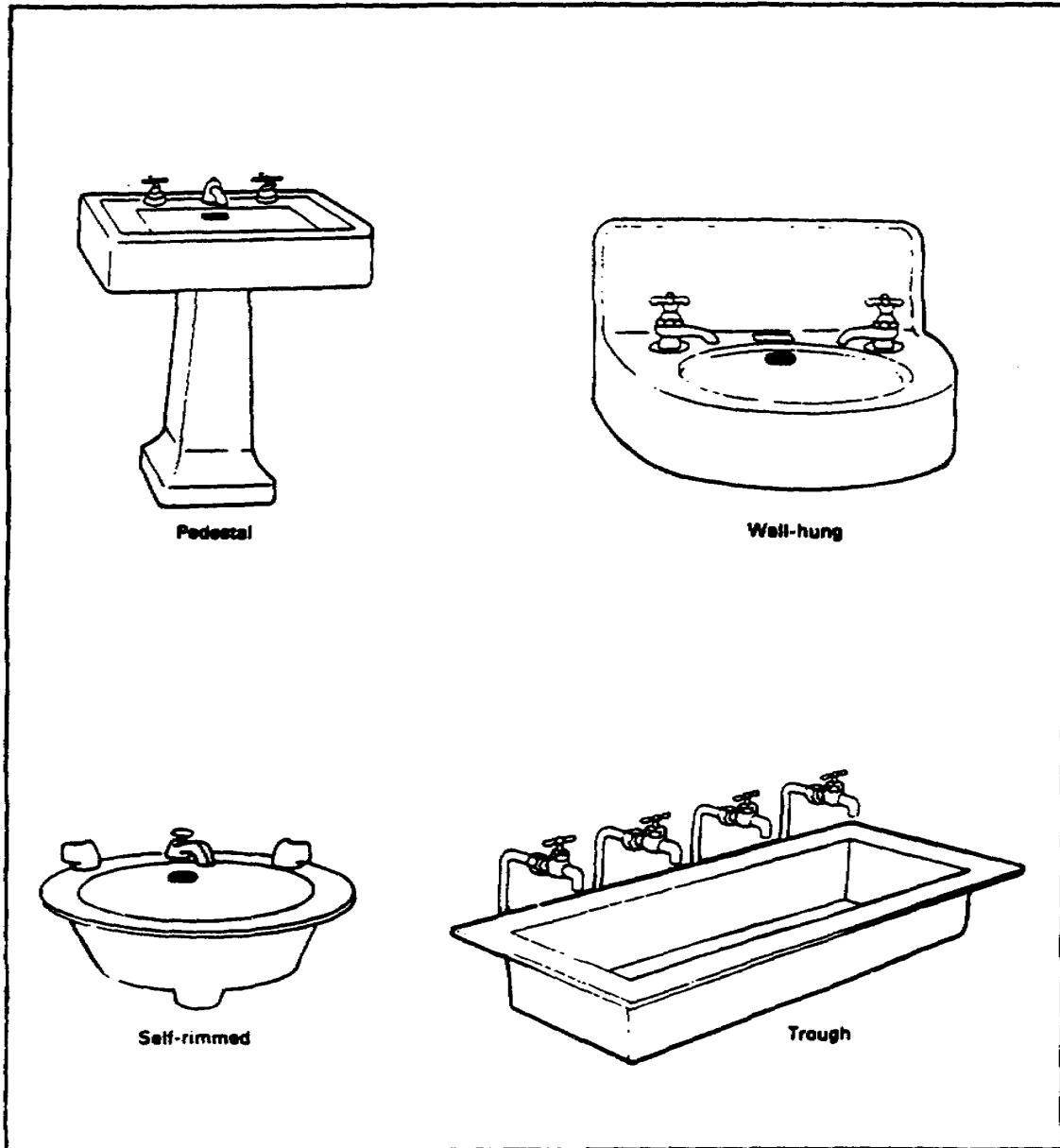

FIGURE 1. LAVATORIES



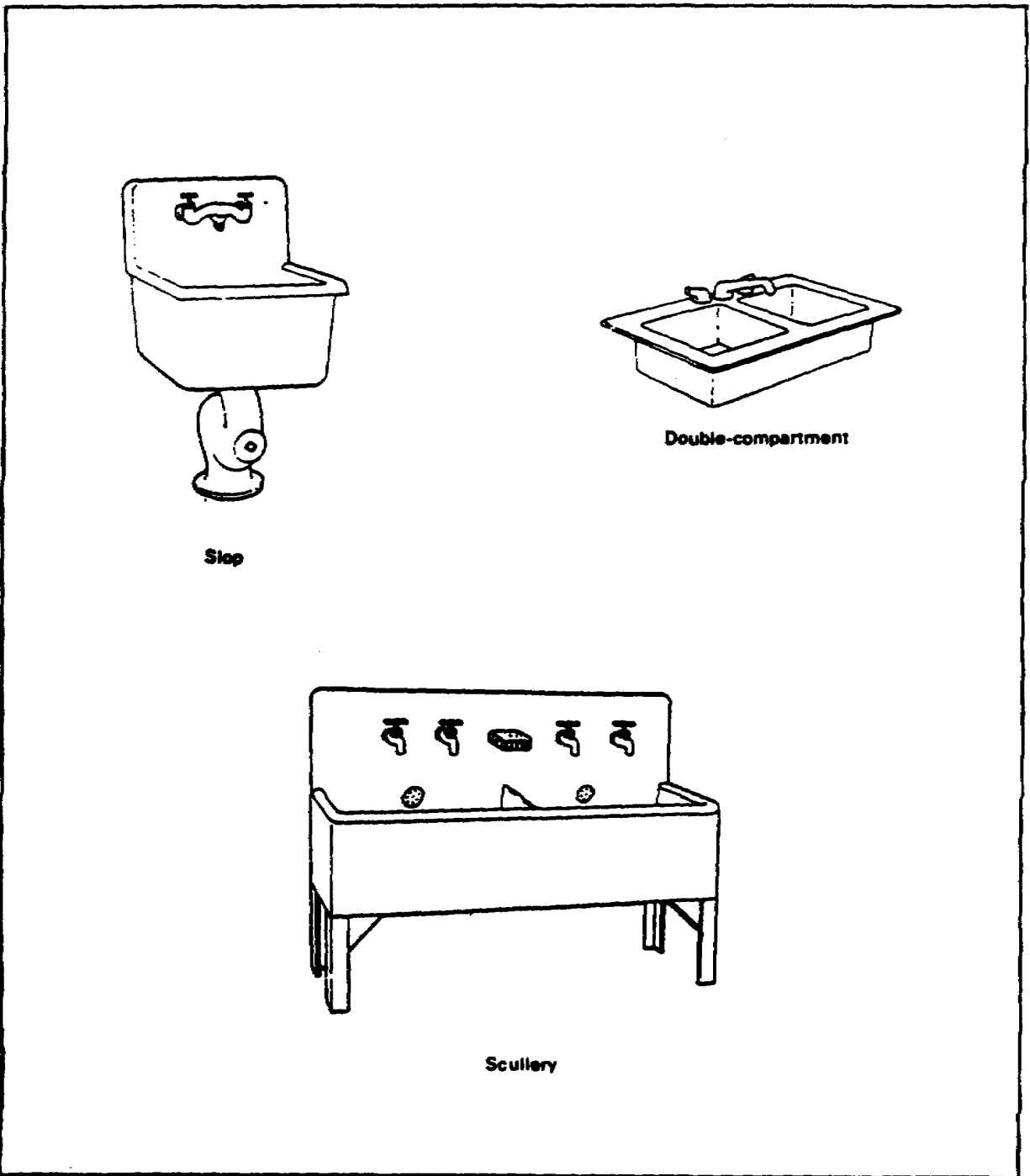

FIGURE 2. SINKS

Lesson 1/Learning Event 1

**Learning Event 1**  
**SELF-CHECK EXERCISE**

Match each lavatory or sink with its description.

- A. Lavatory, trough
- B. Sink, scullery
- C. Lavatory, wall-hung
- D. Sink, slop

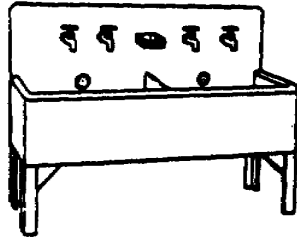

\_\_\_\_\_

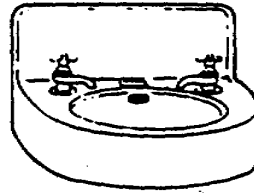

\_\_\_\_\_

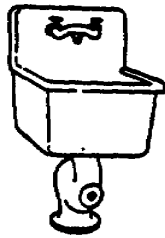

\_\_\_\_\_

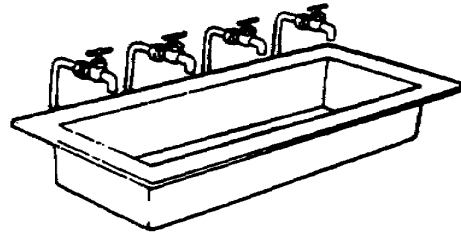

\_\_\_\_\_

**SELF-CHECK EXERCISE SOLUTIONS**

- D. Sink, slop
- C. Lavatory, wall-hung
- B. Sink, scullery
- A. Lavatory, trough

**Learning Event 2:  
INSTALLING WALL-HUNG LAVATORIES**

To install a wall-hung lavatory, you need a mounting board placed between the studs, a mounting bracket to support the lavatory, and the manufacturer's rough-in specifications for the lavatory. You must set the lavatory in place on the mounting bracket. To obtain the measurements for installing the mounting board, the mounting bracket, and the lavatory, always look over the manufacturer's rough-in specifications (see Figure 3).

NOTE: If manufacturer's specifications are not available, you should check the set of construction drawings and/or check with your supervisor.

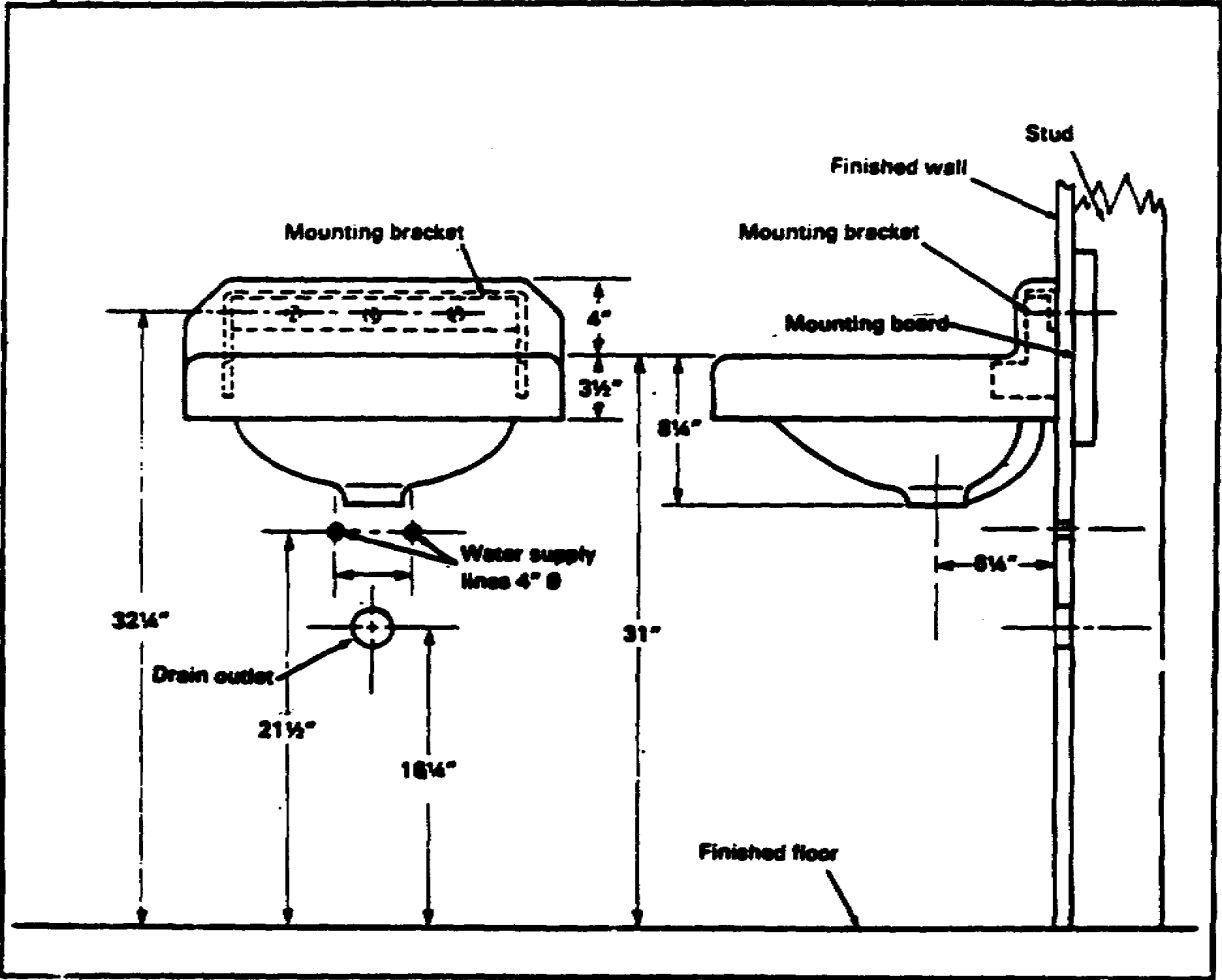

**FIGURE 3. MANUFACTURER'S SPECIFICATIONS**

**Installing the mounting board.** Use the following steps to install the mounting board (see Figure 4).

If the wall is finished, cut out a section so that the two adjoining wall studs can be measured and marked for notches. If the wall is not finished, measure and mark the location of each notch to be cut into each wall stud (see Figure 4-A).

Cut out the notch on each wall stud to the same width and depth as the mounting board to be installed (see Figure 4-B).

Place and nail mounting board to wall studs. Be sure that the board is even with the edge of the wall studs facing you (see Figure 4-C).

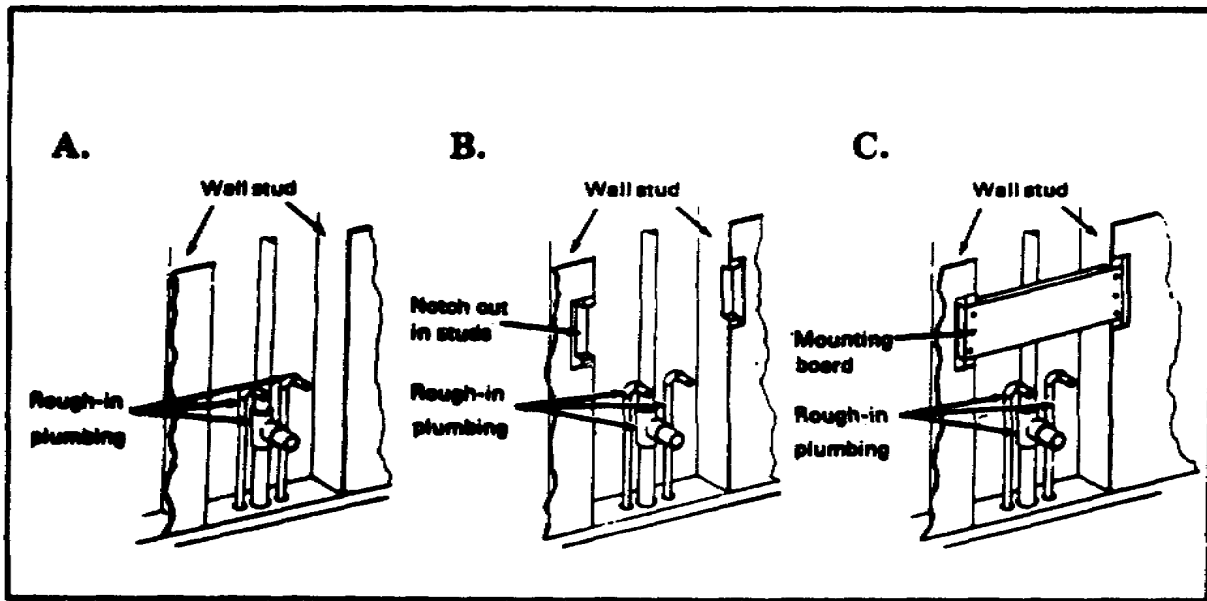
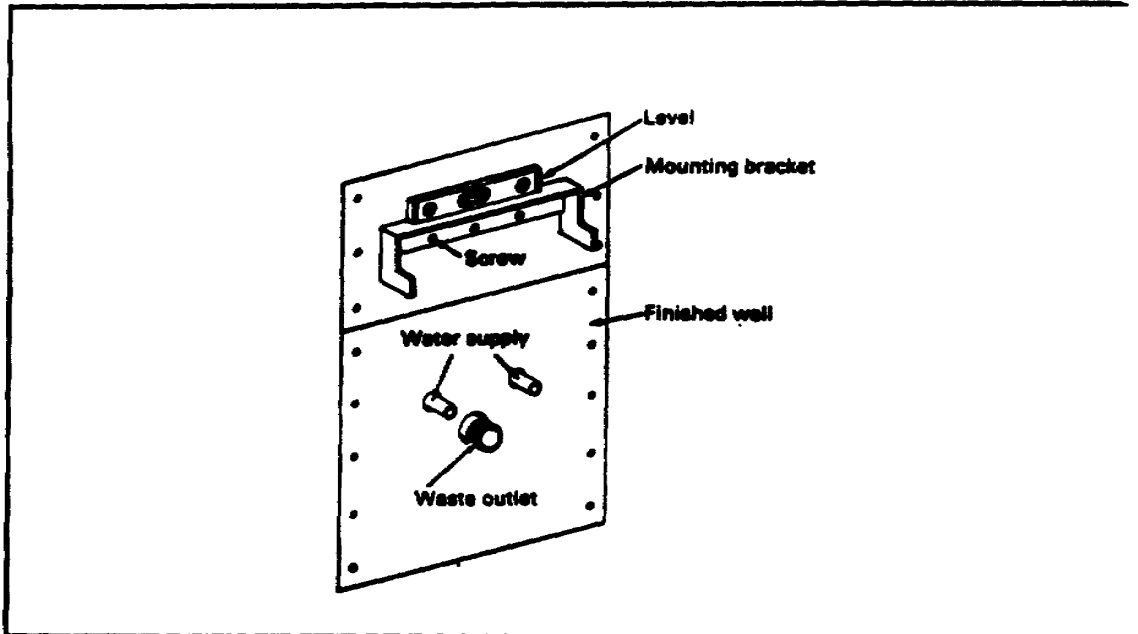

**FIGURE 4. METHOD OF INSTALLING MOUNTING BOARD**

**NOTES:**

1. If wall studs are 2 inches by 4 inches, use 1-inch lumber for mounting board. If wall studs are 2 inches by 6 inches, use 2-inch lumber for mounting board.
2. If a finished wall section was cut out, it must be replaced after the mounting board is installed.

**Installing the mounting bracket.** Use the lavatory's rough-in dimensions to install the mounting bracket. Make sure that the bracket is placed at the right height from floor, and level the bracket with a carpenter's level. Attach the bracket with screw (see Figure 5).



**FIGURE 5. INSTALLATION OF MOUNTING BRACKET**

**Setting the lavatory on the mounting bracket.** Place the lavatory on the mounting bracket by pushing it down gently but firmly as far as it can go. Then check the level of the lavatory with a carpenter's level. Make sure it is level (see Figure 6).

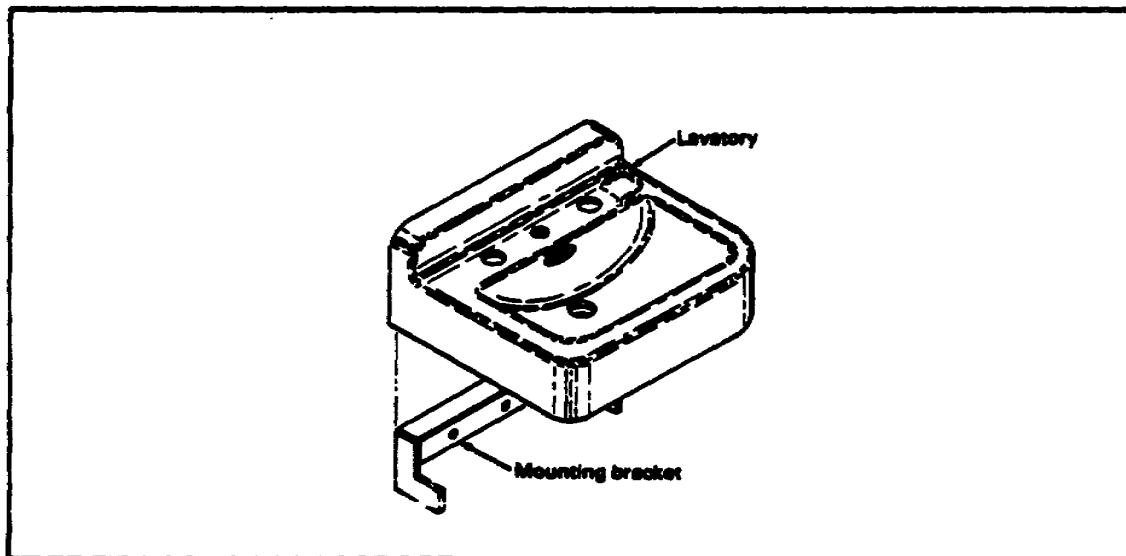
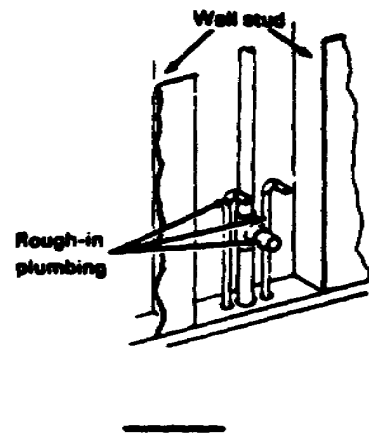
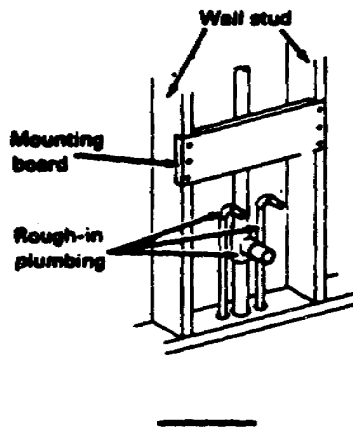
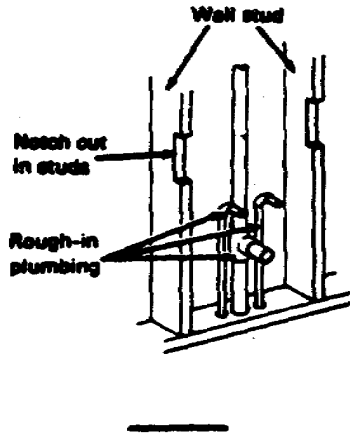

**FIGURE 6. PLACEMENT OF LAVATORY MOUNTING BRACKET**

## Lesson 1/Learning Event 2

### Learning Event 2 SELF-CHECK EXERCISE

1. Match the steps required to install the mounting board.
  - A. If the wall is finished, cut out a section so that the two adjoining wall studs can be measured and marked for notches. If the wall is not finished, measure and mark the location of each notch to be cut into each wall stud.
  - B. Cut out the notch on each wall stud to the same width and depth the mounting board to be installed.
  - C. Place and nail mounting board to wall studs. Make sure that the mounting board is even with the edge of the wall studs facing you.



Solutions for this exercise are on page 9.

Fill in the blanks with your responses.

2. The notch cut into each wall stud has to be the same \_\_\_\_\_ and \_\_\_\_\_ as the mount board to be installed.
3. The mounting board is \_\_\_\_\_ with the edge of the \_\_\_\_\_ facing you.
4. The mounting bracket must be placed at the right \_\_\_\_\_ from the floor.
5. The mounting bracket must be set in a \_\_\_\_\_ position.
6. The lavatory is pushed down on the mounting bracket \_\_\_\_\_ but \_\_\_\_\_.
7. Check the lavatory on the mounting bracket to ensure that it is \_\_\_\_\_.

**SELF-CHECK EXERCISE SOLUTIONS**

1. B  
C  
A
2. Depth, width
3. Even, wall studs
4. Height
5. Level
6. Gently, firmly
7. Level

## Lesson 1/Learning Event 3

### Learning Event 3: INSTALLING FAUCETS

There are many types and styles of faucets. When attaching a single or combination faucet to a lavatory or sink, follow the manufacturer's instructions. All faucets are attached to a lavatory/sink in basically the same manner. Use the following steps to install a single or combination faucet (see Figure 7):

Apply plumber's putty to the bottom of the faucet.

Set the faucet in the holes provided for the faucets.

From under the lavatory/sink, slide a washer on each threaded end, and screw the locknuts on until they are hand-tight.

Using a basin wrench, tighten the locknuts.

Wipe off all excess plumber's putty around the base of the faucet.

**NOTE:** If the combination faucet comes with a gasket, plumber's putty is not applied to the base.

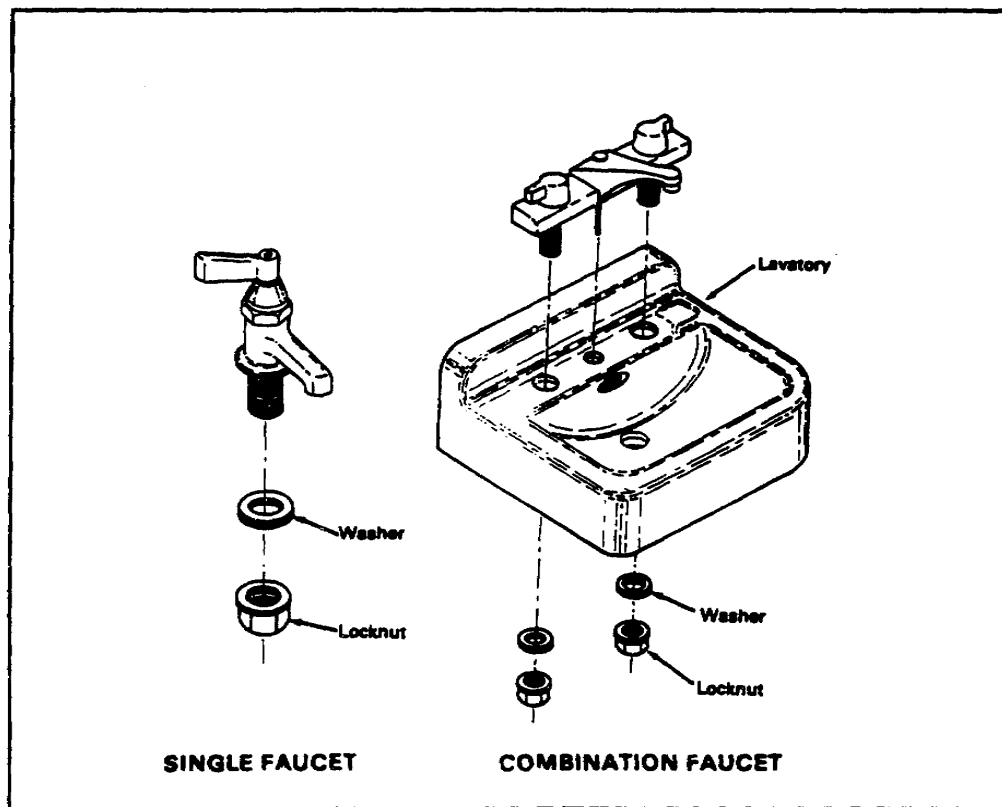
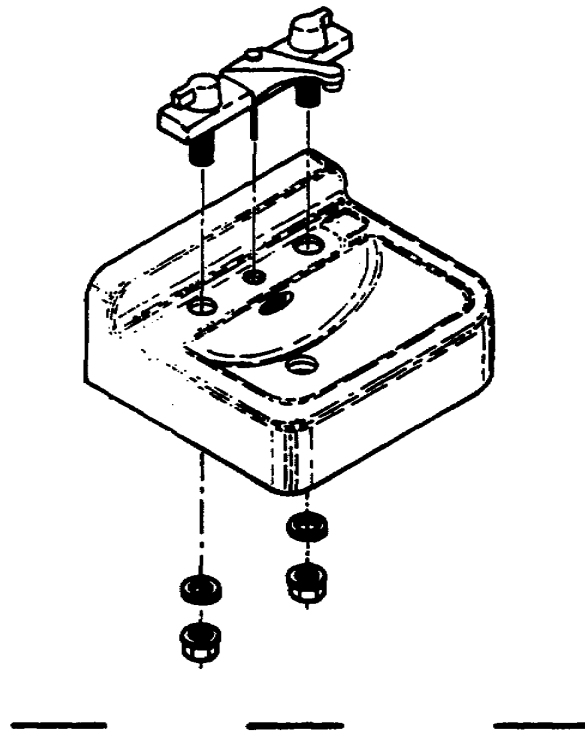

FIGURE 7. INSTALLATIONS OF FAUCETS



**Learning Event 3**  
**SELF-CHECK EXERCISE**

1. List the correct order of installing a combination faucet on a lavatory.
  - A. Screw locknut on faucet threads hand-tight, and tighten with a basin wrench.
  - B. Apply plumber's putty to bottom of faucet, and set faucet on lavatory.
  - C. Slide washer over threaded ends of faucet.



Fill in the blank with your response.

2. When the combination faucet comes with a \_\_\_\_\_, plumber's putty is not applied on the bottom of the faucet.

**SELF-CHECK EXERCISE SOLUTIONS**

1. B  
C  
A
2. Gasket

## Lesson 1 / Learning Event 4

### Learning Event 4: ATTACHING DRAIN OUTLETS

A drain outlet attachment to a lavatory/sink is the first step in installing the fixture's draining system. The drain outlet hookup is a combination of parts that are assembled to the lavatory/sink. The two types of attachments are the pullout (PO) plug type and the popup type.

***Pull-out ( type of outlet attachment.*** Use the following steps for PO type outlet attachment (see Figure 8):

Attach the drain body to a lavatory/sink by applying a bead of plumber's putty under the rim of the flange and placing it into the drain outlet.

Press the flange down to spread the plumber's putty.

Slip the rubber washer and the metal washer over the drain body under the fixture.

Screw the locknut clockwise into the drain body.

Wipe off all excess plumbers putty from around the flange.

Apply pipe compound to the threads of the drain body, and screw the tailpiece on the drain body.

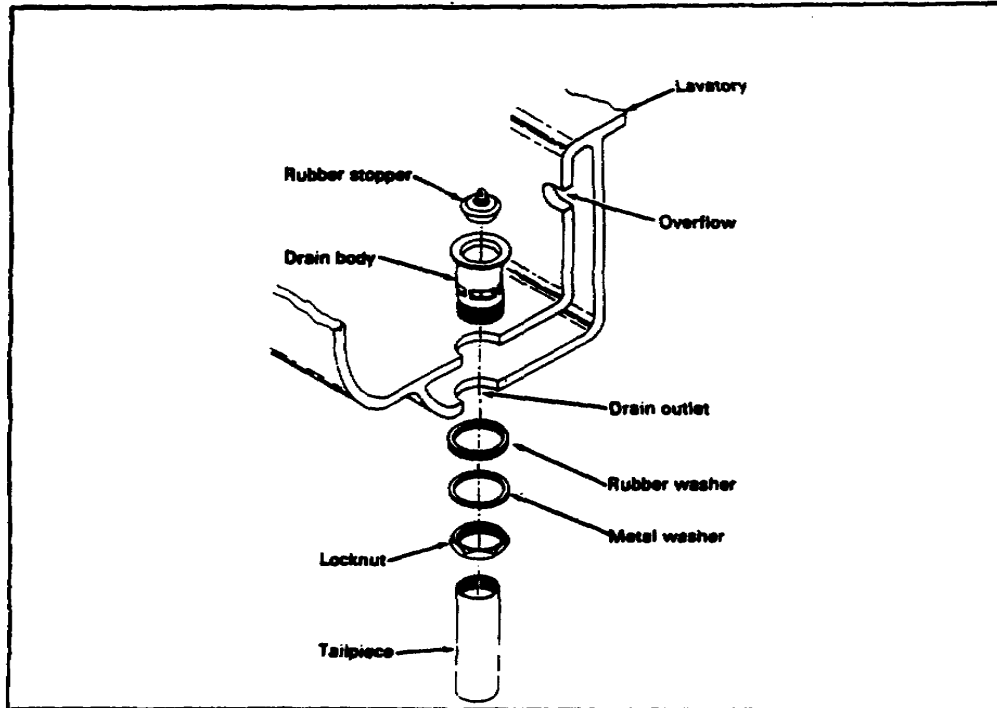

FIGURE 8. PULL-OUT (PO) PLUG OUTLET ATTACHMENTS

**Pop-up type of outlet attachment.** Use the following steps to attach a pop-up drain (see Figure 9):

Apply pipe joint compound to the upper drain body, and screw the flange onto the drain body.

Apply plumber's putty under the rim of the flange, and place it into the drain outlet.

Press down on flange to spread the plumber's putty.

Slip the rubber washer and metal washer over the drain body under the fixture.

Screw the locknut hand-tight onto the drain body, and tighten the locknut with a wrench.

Following manufacturer's instructions, install the pop-up mechanism into the drain tee.

Apply joint compound to the lower threads of the drain body, and screw the drain tee onto the body. Make sure the pop-up pivot rod faces the rear center of the fixture.

Apply pipe joint compound to the tailpiece threads, and screw the tailpiece onto the drain tee.

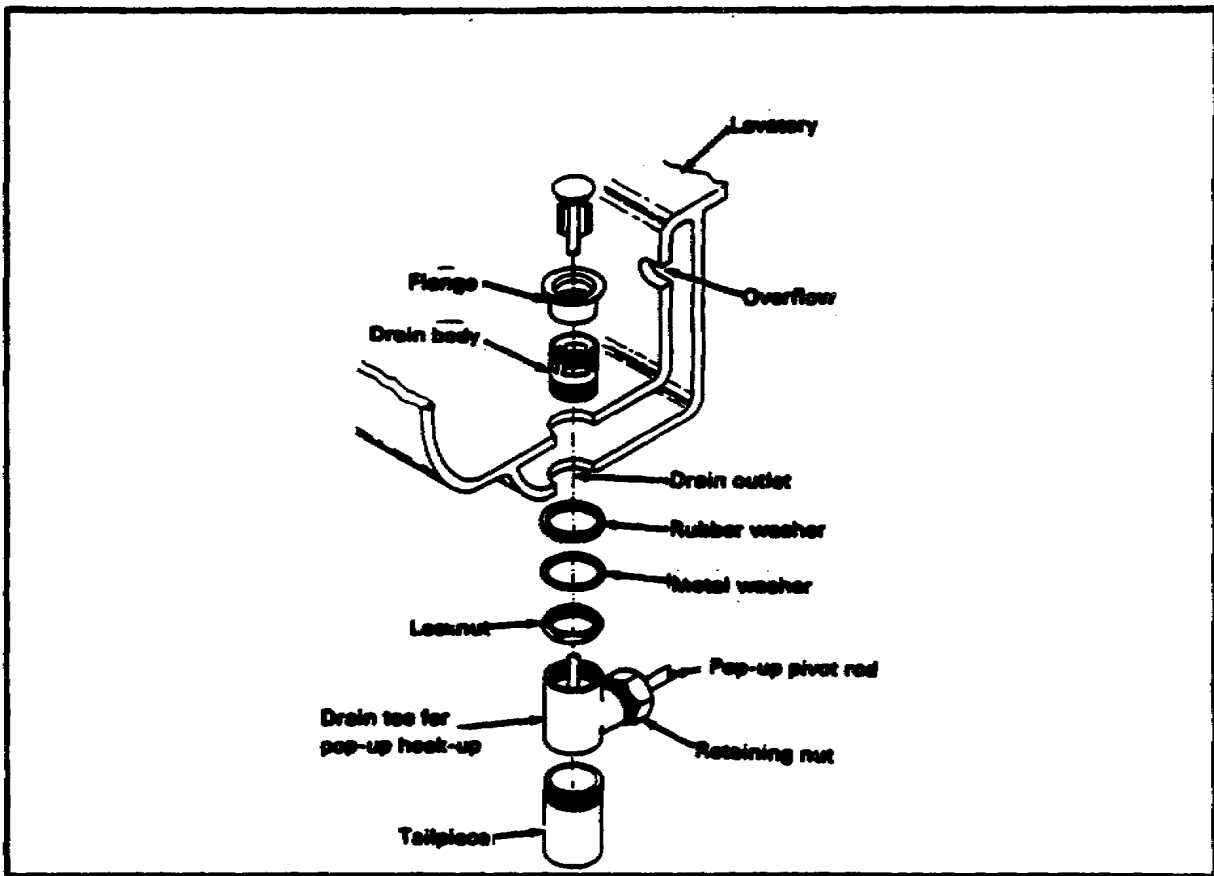

FIGURE 9. POP-UP PLUG OUTLET ATTACHMENTS

## Lesson 1/Learning Event 4

***Kitchen sink drain outlet attachment.*** Use the following steps to attach a strainer type drain (see Figure 10):

Apply plumber's putty to the bottom of the flange, and set the drain body into the drain outlet.

Press the drain body down firmly to spread the plumber's putty.

Slip the gasket and the metal washer onto the drain body under the sink.

Screw the locknut hand-tight onto the drain body, and tighten it with a wrench.

Wipe off all excess plumber's putty from around the flange.

Slide the coupling nut onto the tailpiece.

Using both hands, slide the plastic sleeve onto the drain body, and attach the tailpiece by screwing the coupling nut hand-tight onto the drain body.

Tighten nut with a wrench.

**NOTE:** Attach all lavatory or sink drain outlets using manufacturer's instructions.

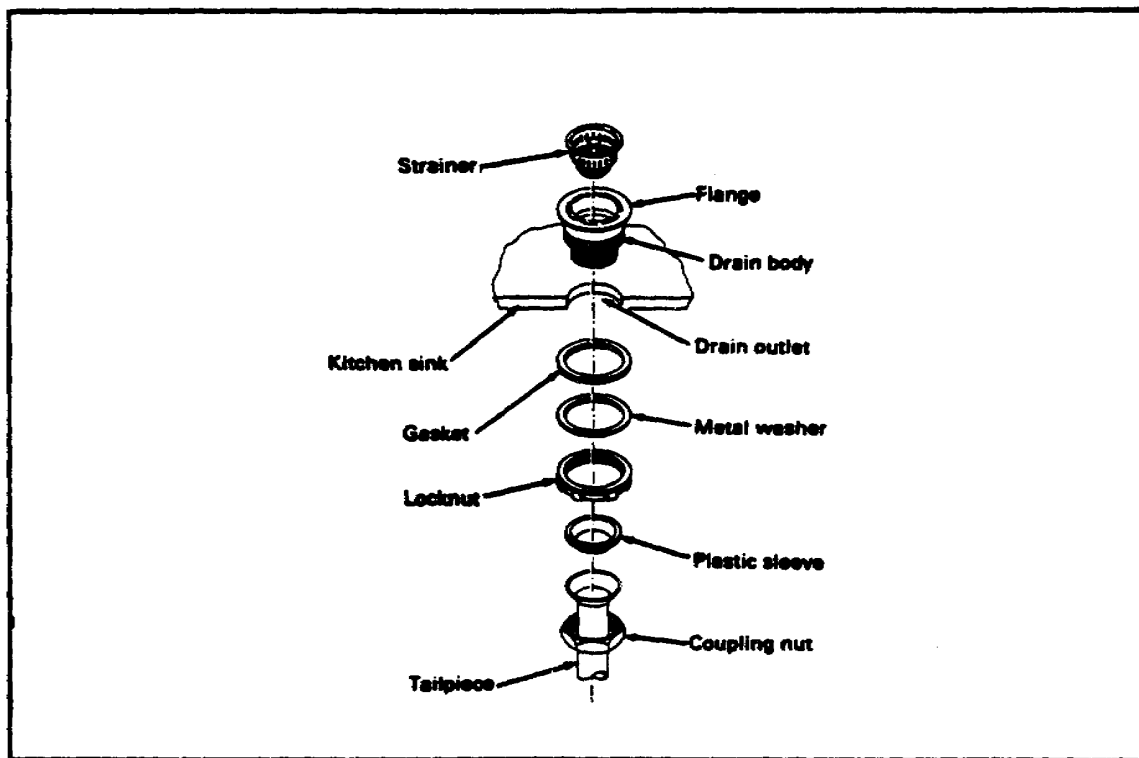
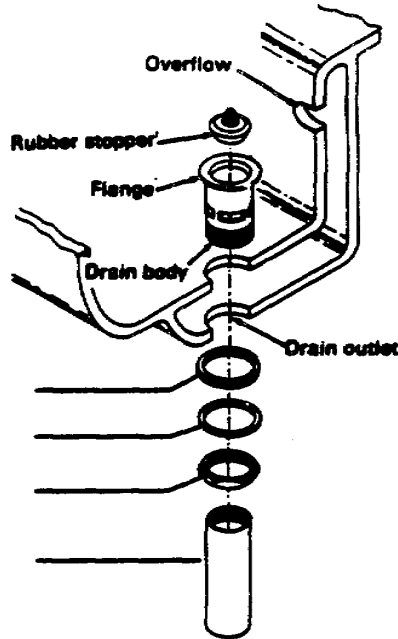

FIGURE 10. KITCHEN SINK OUTLET ATTACHMENTS

**Learning Event 4**  
**SELF-CHECK EXERCISE**

1. What material is applied under the flange for installation onto a lavatory and/or sink?
  - A. Rubber gasket
  - B. Rubber washer
  - C. Plumber's putty
  - D. Pipe joint compound
  
2. Match the items that are attached underneath the lavatory in the correct order of installation for a pullout (PO) type plug.
  - A. Metal washer
  - B. Rubber washer
  - C. Tailpiece
  - D. Locknut



**SELF-CHECK EXERCISE SOLUTIONS**

1. C. Plumber's putty
2. B. Rubber washer  
A. Metal washer  
D. Locknut  
C. Tailpiece

## Lesson 1/Learning Event 4

3. Match the items that are attached underneath the lavatory in the correct order of installation for a pop-up type plug.

- A. Metal washer
- B. Rubber washer
- C. Locknut
- D. Tailpiece
- E. Drain tee

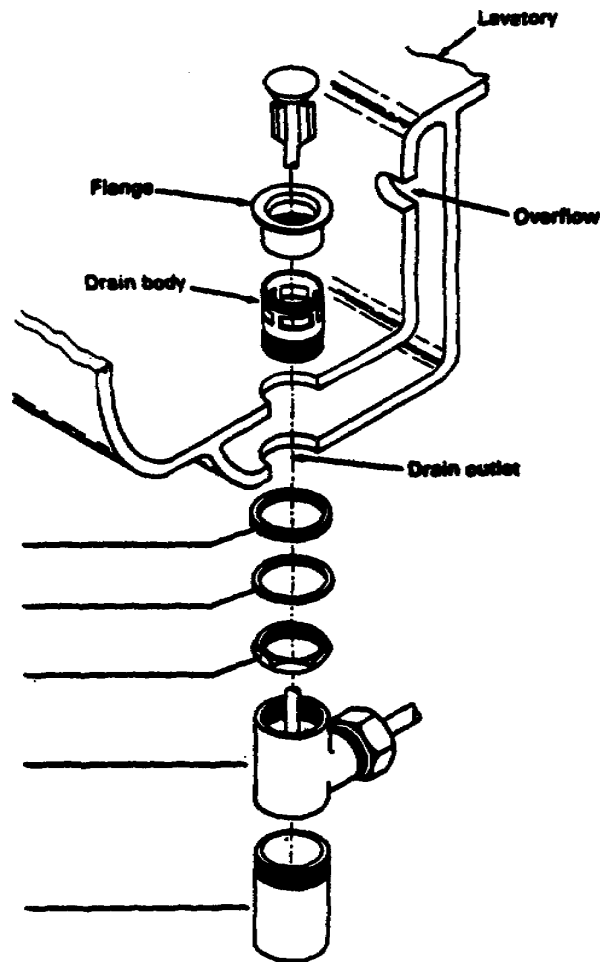

### SELF-CHECK EXERCISE SOLUTIONS

3. B. Rubber washer  
A. Metal washer  
C. Locknut  
E. Drain tee  
D. Tailpiece

4. Match the items that are attached underneath a kitchen sink in the correct order of installation.

- A. Plastic sleeve
- B. Gasket
- C. Metal washer
- D. Tailpiece
- E. Locknut
- F. Coupling nut

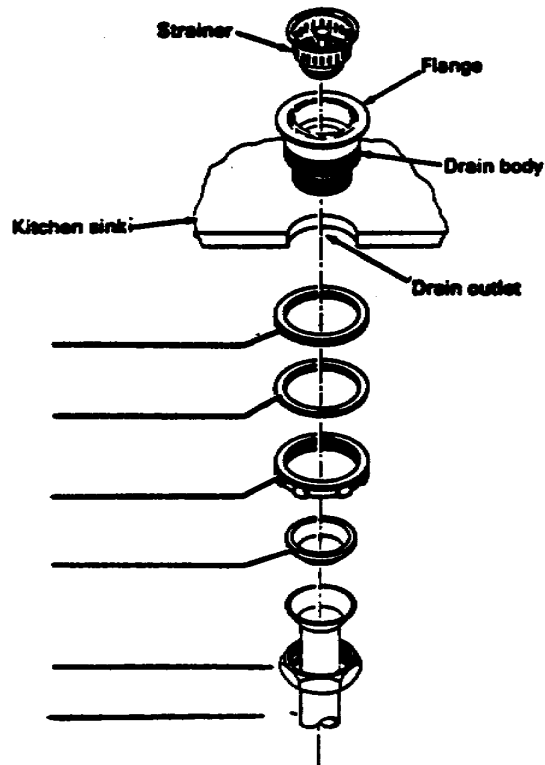

**SELF-CHECK EXERCISE SOLUTIONS**

- 4. B. Gasket
- C. Metal washer
- E. Locknut
- A. Plastic sleeve
- F. Coupling nut
- D. Tailpiece

## Lesson 1 / Learning Event 5

### Learning Event 5: INSTALLING P-TRAPS

A lavatory/sink waste connection from the tailpiece to the rough-in plumbing drain outlet is made by using a P-trap. The P-trap is formed using the following parts: U-shaped trap, drainpipe with one curved end, and three slip nuts and washers. P-traps come in two types and sizes: fixed or swiveled and 1¼ inches or 1½ inches.

**Installing a P-trap.** Use the following steps to connect the lavatory/sink P-trap (see Figure 11):

Slide escutcheon, slip nut, and rubber washer over the straight end of the drainpipe.

Slide straight end of drainpipe into rough-in plumbing.

Fasten slip nut hand-tight onto rough-in plumbing.

Slide slip nuts and then rubber washers over curved end of drainpipe and tailpiece.

Slide trap's lowest end onto drainpipe and highest end onto tailpiece.

Fasten slip nuts hand-tight onto trap.

Line up the connections, and tighten all slip nuts.

Slide escutcheon against the wall.

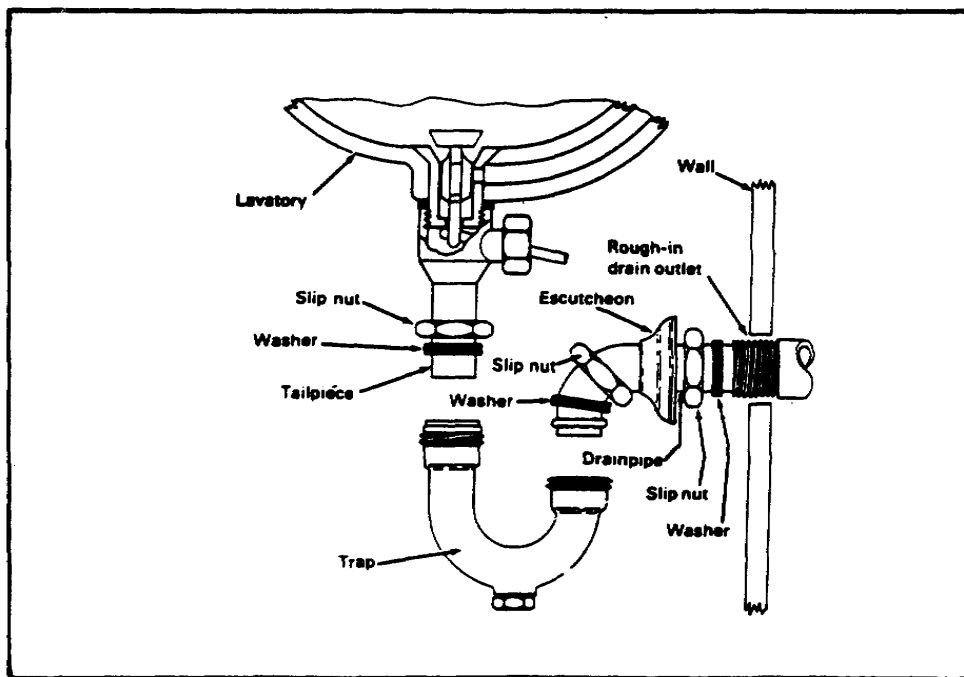

FIGURE 11. INSTALLING A P-TRAP



**Learning Event 5**  
**SELF-CHECK EXERCISE**

Identify each item that is used to install a P-trap.

- A. \_\_\_\_\_
- B. \_\_\_\_\_
- C. \_\_\_\_\_
- D. \_\_\_\_\_

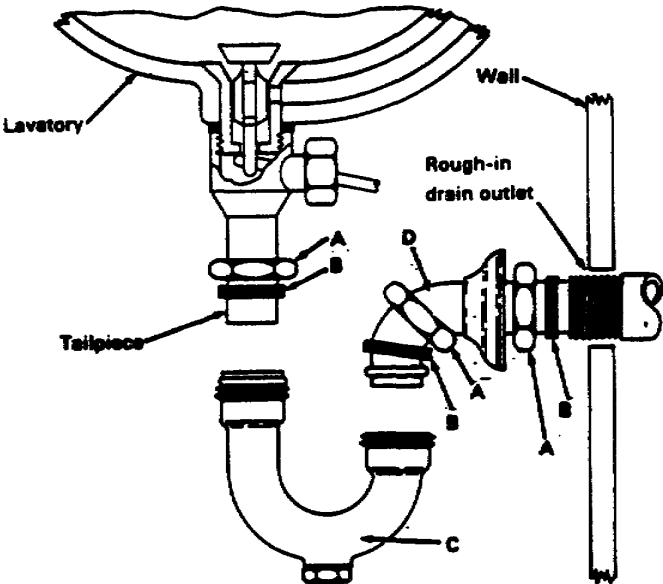

**SELF-CHECK EXERCISE SOLUTIONS**

- A. Slip nut
- B. Washer
- C. Trap
- D. Drainpipe

## Lesson 1 /Leaning Event 6

### Learning Event 6: INSTALLING SHUTOFF ANGLE VALVES

A lavatory/sink requires both hot- and cold-water supply service. The water service plumbing is connected from the rough-in water lines to shutoff valves and from the valves to the hot- and cold-water faucets. When the rough-in plumbing comes out from the wall, use shutoff angle valves. When the rough-in plumbing comes up through the floor, use straight shutoff valves.

**Installing shutoff angle valves to steel pipe.** Use the following steps to install angle valve on threaded galvanized pipe (see Figure 12):

Check and clean the threads of the rough-in water pipe.

Slide the escutcheon on the pipe, and push it against the finished wall. Coat threads with pipe joint compound.

Screw angle valve hand-tight on threads, and then tighten with wrench. Make sure the valve's other opening is facing up towards the faucets.

Set valve in closed position.

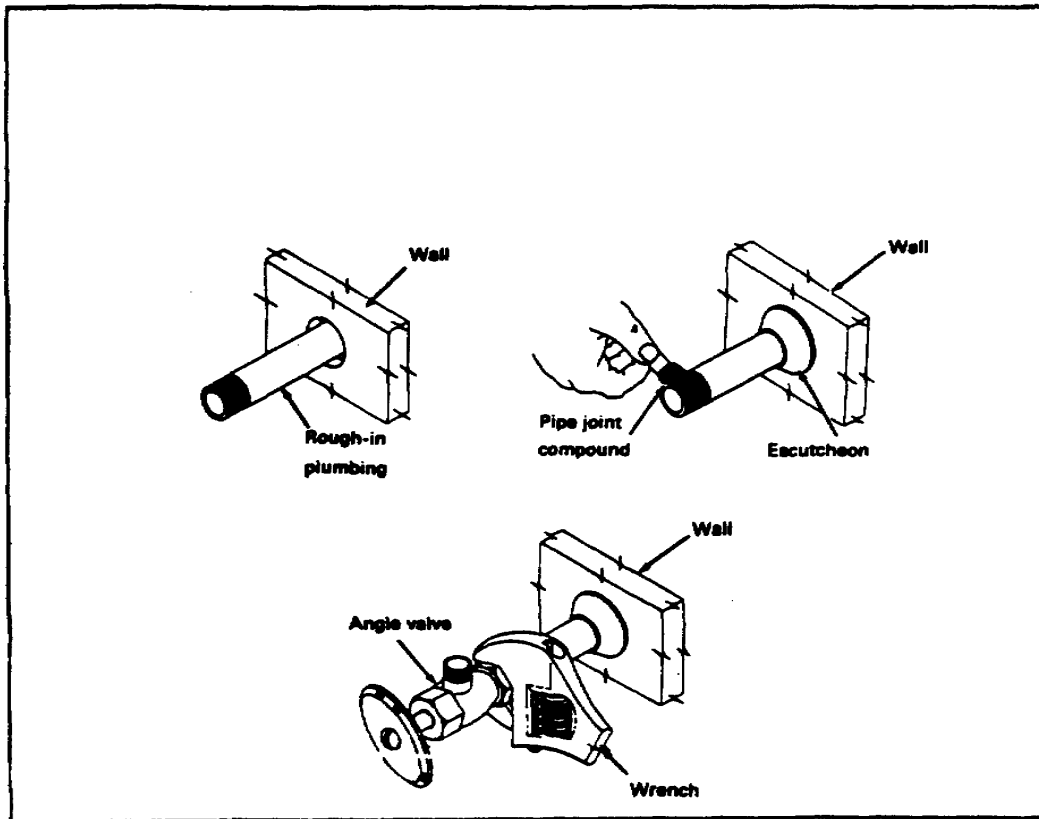

FIGURE 12. INSTALLING SHUT OFF ANGLE VALVE, STEEL PIPE

**Installing shutoff angle valves to rigid copper tubing.** Use the following steps to install an angle valve to rigid copper tubing (see Figure 13):

Check and clean the copper tubing.

Slide the escutcheon, coupling nut, and compression ring onto the tubing.

Slide the valve onto the tubing, and screw the coupling nut hand-tight onto the valve. Tighten coupling nut with a wrench. Make sure the valve's other opening is facing up towards the faucets.

Set valve in closed position.

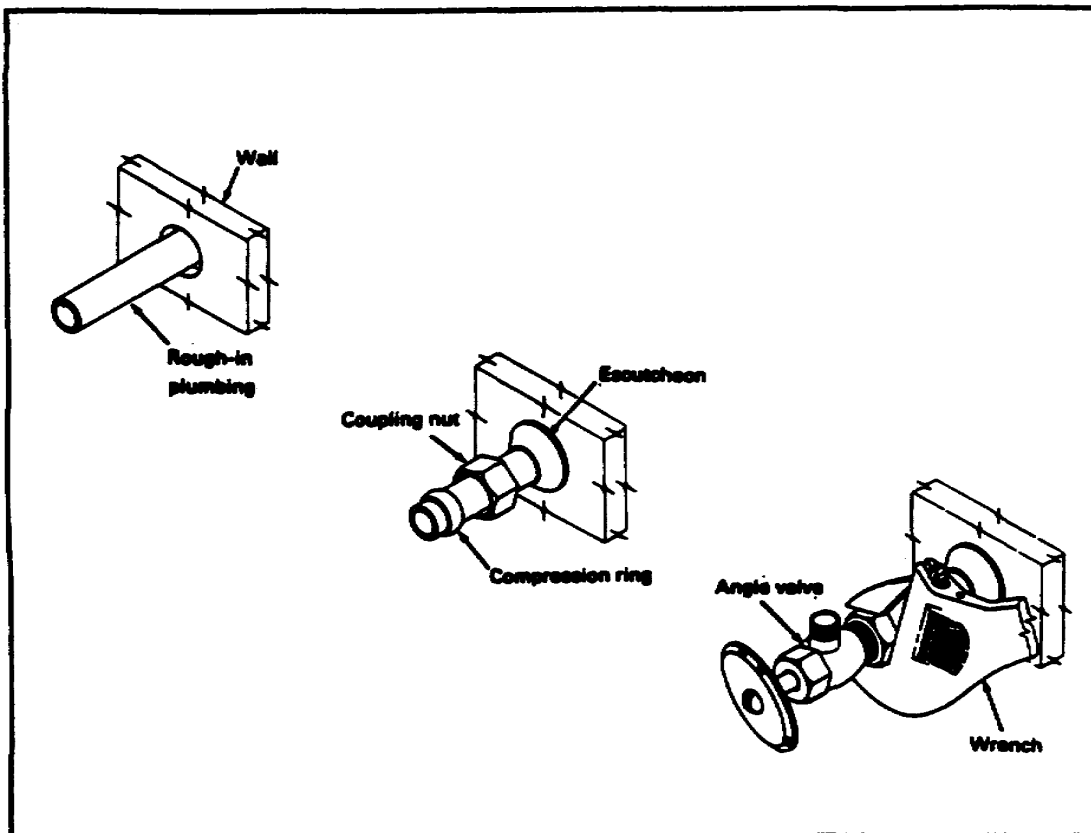

FIGURE 13. INSTALLING SHUTOFF ANGLE VALVE, COPPER PIPE

## Lesson 1/Learning Event 6

Installing shutoff angle valves to plastic pipe. Use the following steps to install a shutoff angle valve to plastic pipe (see Figure 14):

Clean and apply primer around the outside end of the rough-in plumbing.

Apply solvent cement around the outside end of the rough-in plumbing.

Apply solvent around the outside of the smooth end of the male adaptor, and push it onto the end of the rough-in plumbing.

Apply pipe joint compound to the shutoff valve threads, and screw valve hand-tight into the female adaptor.

Tighten connection using two wrenches: one to hold the adaptor, the other to tighten the valve connection. Make sure the valve's other opening is facing up toward the faucet.

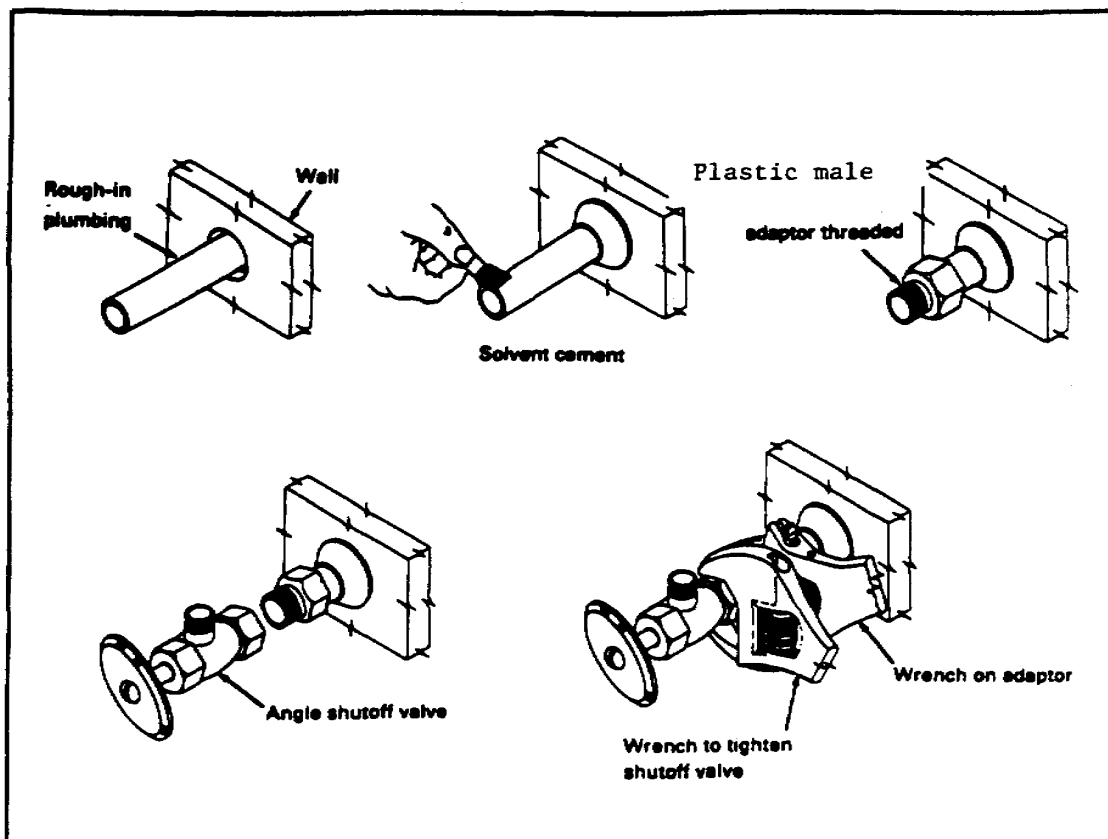
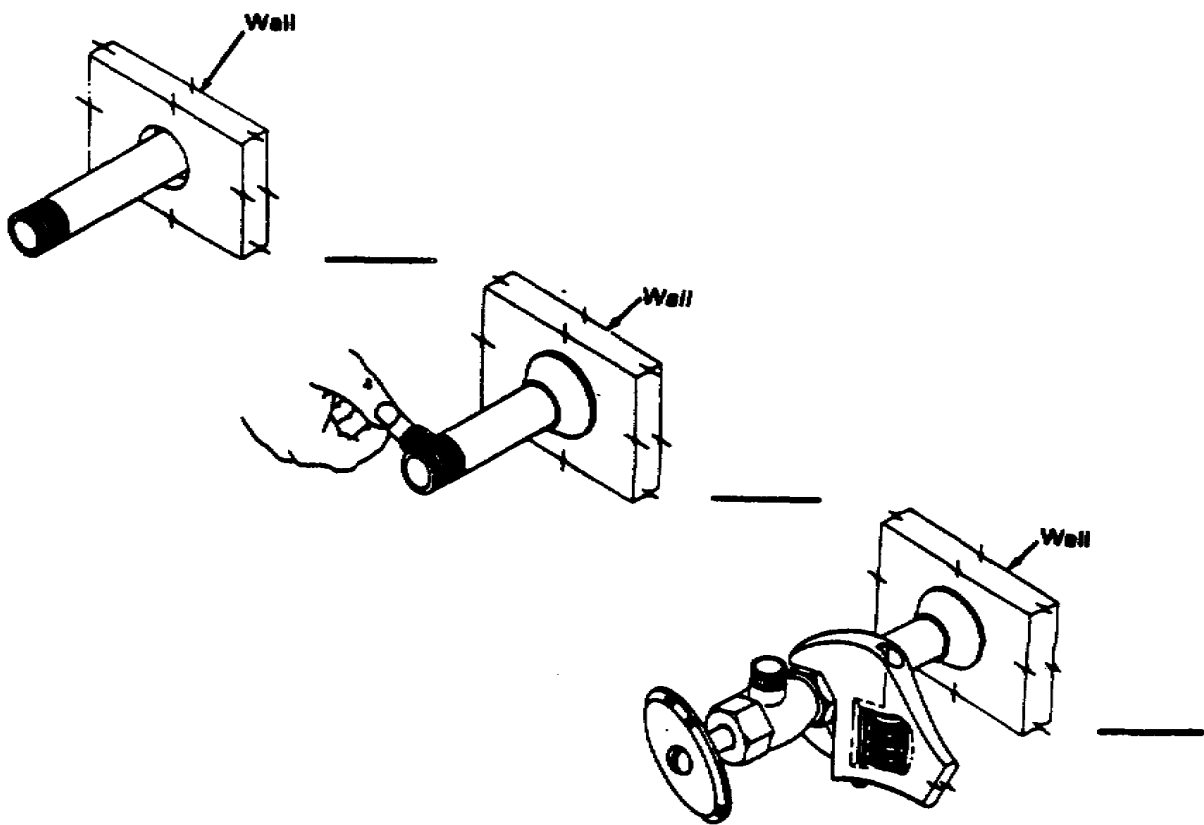

FIGURE 14. INSTALLING SHUTOFF ANGLE VALVE, PLASTIC PIPE

**Learning Event 6**  
**SELF-CHECK EXERCISE**

1. Match steps in the correct order to install a shutoff angle valve to galvanized steel pipe.
  - A. Screw angle valve on hand-tight, and tighten with a wrench.
  - B. Check and clean threads of rough-in water pipe.
  - C. Slide escutcheon on pipe to wall, and coat pipe threads with pipe joint compound.



**SELF-CHECK EXERCISE SOLUTIONS**

1. B  
C  
A

## Lesson 1/Learning Event 6

2. Match the steps in the correct order to install a shutoff angle valve to rigid copper tubing.

A. Slide valve onto tubing, and screw coupling nut hand-tight on valve. Tighten nut with a wrench.

B. Check and clean end of rough-in water line.

C. Slid escutcheon, coupling nut, and compression ring onto the tubing.

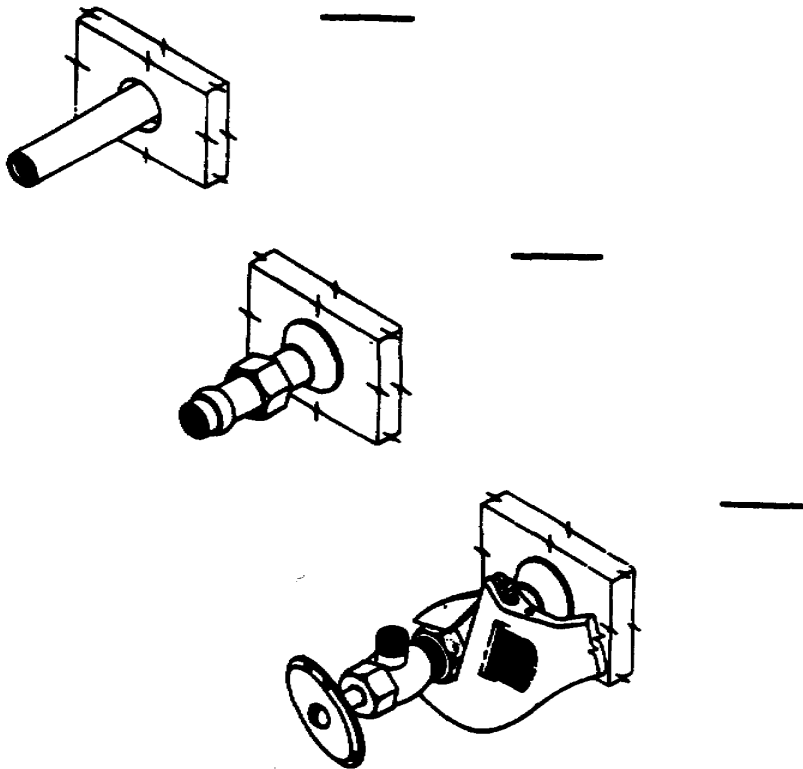

### SELF-CHECK EXERCISE SOLUTIONS

2. B  
C  
A

3. Match the steps in the correct order to install a shutoff angle valve to plastic pipe.

A. Apply pipe joint compound to the shutoff male adapter, and screw valve hand-tight into the female adaptor.

B. Clean and apply primer around the outside end of the rough-in plumbing.

C. Tighten connection using two wrenches: one to hold the adaptor, the other to tighten the valve connection. Make sure valve's other opening is facing up toward the faucet.

D. Apply solvent around the inside of the smooth end of the female adaptor, and push it onto the end of the rough-in plumbing.

E. Apply solvent cement around the outside end of the rough-in plumbing.

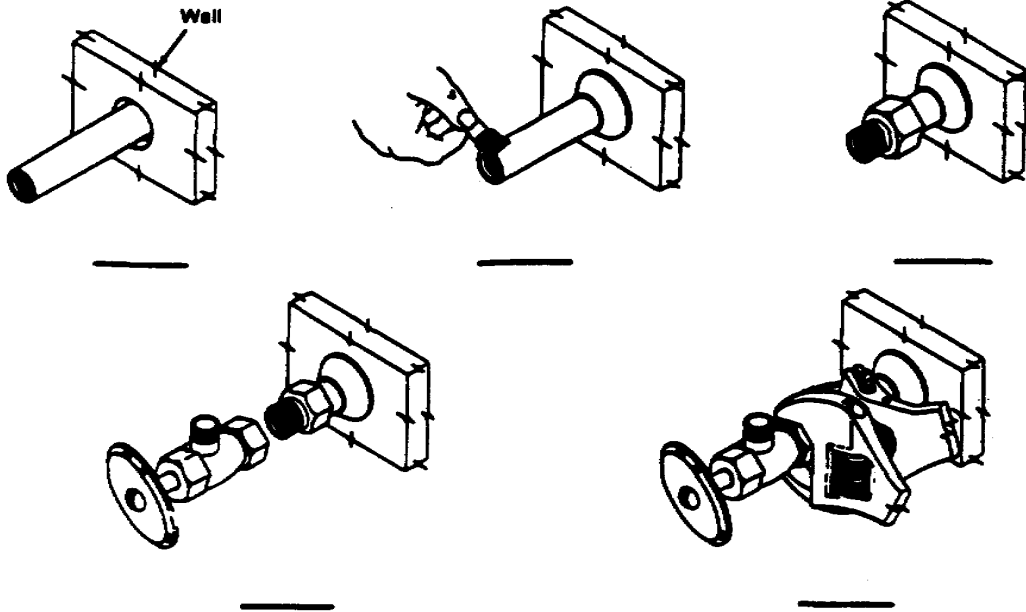

**SELF-CHECK EXERCISE SOLUTIONS**

3. B  
E  
D  
A  
C

## Lesson 1/Learning Event 7

### Learning Event 7: INSTALLING FLEXIBLE TUBING

The hot- and cold-water flexible water supply connections are from the shutoff valves to the threaded end of each faucet. The flexible tube comes in several lengths and is made of chrome-plated copper. The tubes are bent to fit and attached with coupling nuts.

***Bending flexible tubing.*** Use the following steps to bend flexible tubing (see Figure 15):

Slide the flexible tubing into the correct spring bender.

Place both hands on the spring bender, and apply pressure until it is bent as you want it.

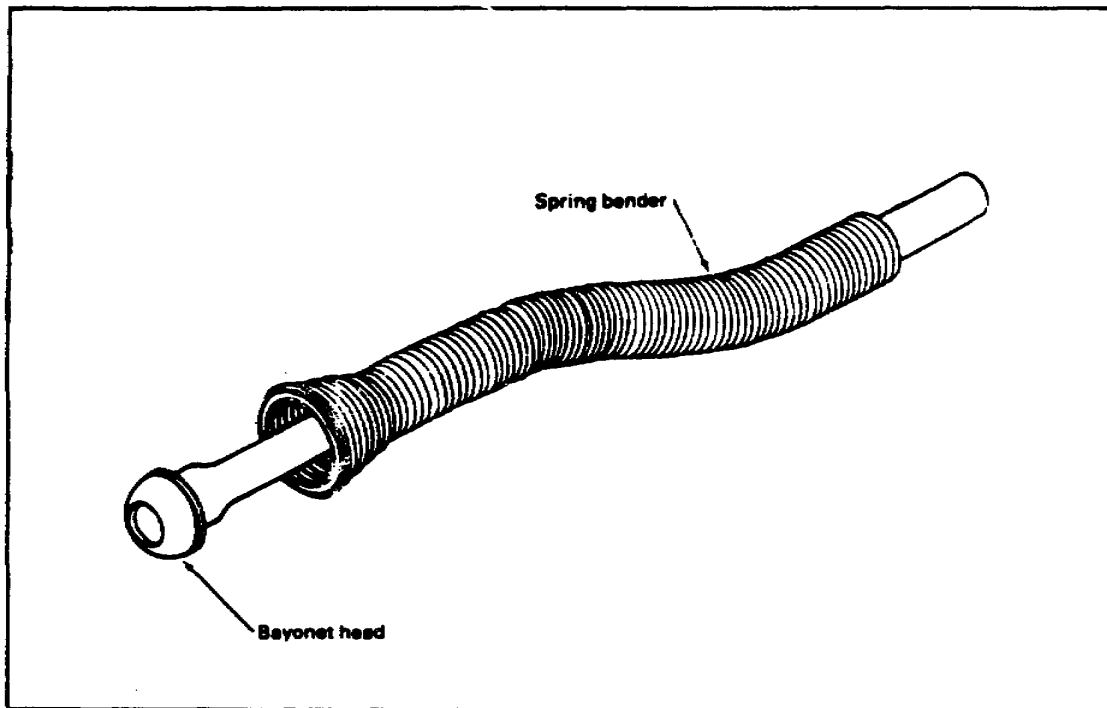

**FIGURE 15. BENDING FLEXIBLE TUBING**

**NOTE:** Spring benders come in a set with several diameter sizes.



*Installing the flexible tube connector for water service.* Use the following steps to install the flexible tube connector (see Figure 16):

Slide coupling nut onto tube up to the bayonet head.

Screw coupling nut hand-tight onto faucet threads, and tighten with a basin wrench.

Slide coupling nut and compression ring onto the lower end of tube, and place tube into shutoff valve.

Screw coupling nut hand-tight onto valve, and tighten with a wrench.

**NOTES:**

1. This method of its installation is for both hot-water (left side) and cold-water (right side) water service lines.
2. If the tube is too long to connect to the shutoff valve, cut it to get a good fit.

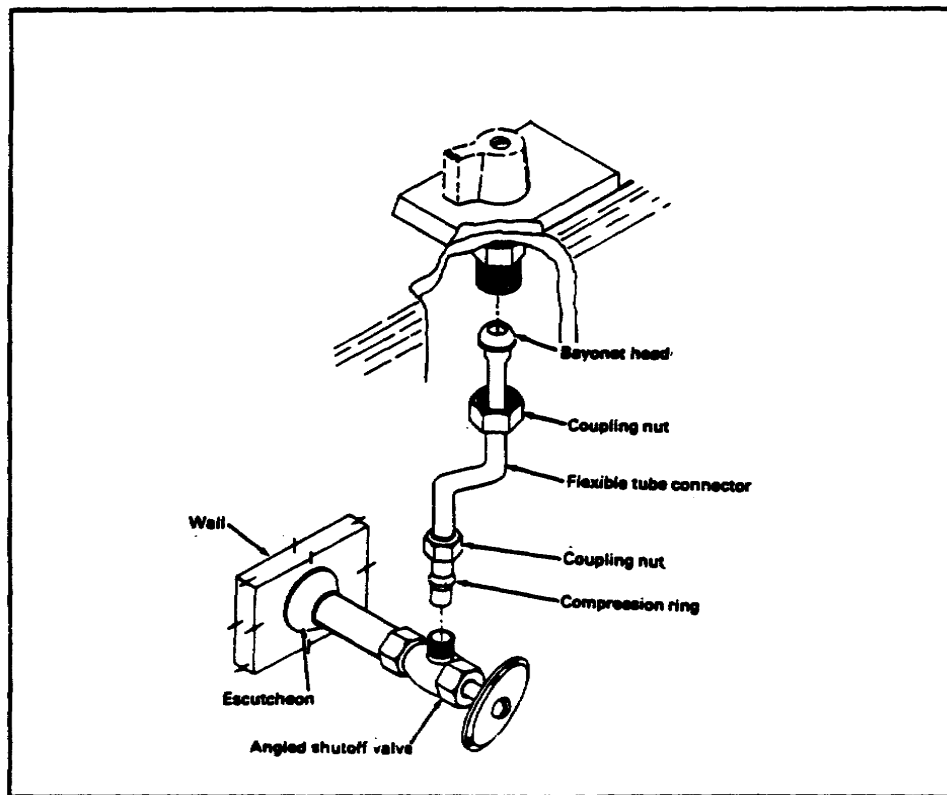

**FIGURE 16. INSTALLING FLEXIBLE TUBING**

## Lesson 1/Learning Event 7

### Learning Event 7 SELF-CHECK EXERCISE

Fill in the blank with your response.

1. The flexible tubing is \_\_\_\_\_ as you want it with a spring bender for proper installation.
2. Using the letters A, B, C, and D, list the correct order for installing the flexible tubing.
  - A. Slide coupling nut and compression ring onto tubing.
  - B. Screw coupling nut on hand-tight and tighten with a basin wrench.
  - C. Slide coupling nut onto tube up to the bayonet head.
  - D. Screw coupling nut hand-tight onto shutoff valve, and tighten with a wrench.

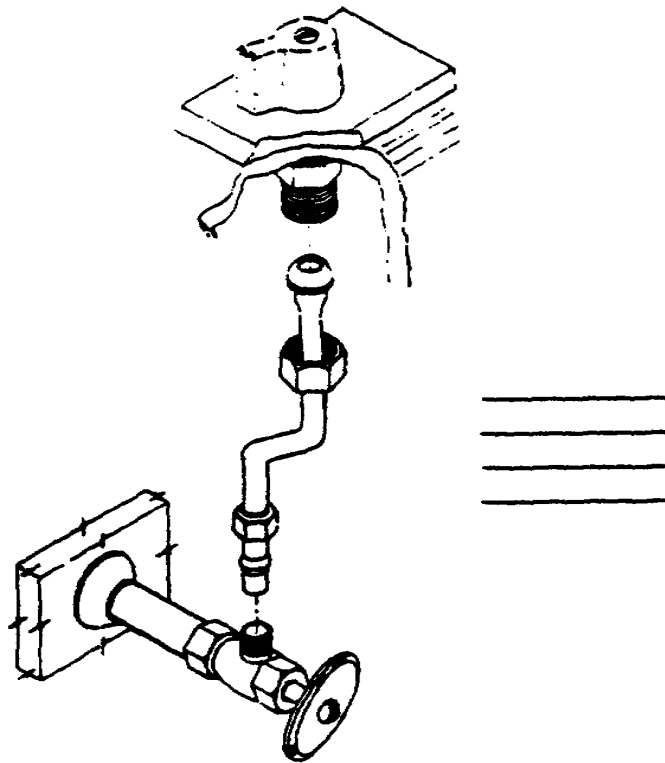

### SELF-CHECK EXERCISE SOLUTIONS

1. Bent
2. C  
B  
A  
D

**Learning Event 8:  
TESTING FOR MECHANICAL  
OPERATION AND LEAKS**

The installation of a new lavatory/sink requires that the fixture be tested for mechanical operation and leaks. Check the operation of each faucet and water retaining plug, such as PO and pop-up type. Then check all water and waste joint connections for leaks, as follows (see Figure 17):

Turn on water at meter stop valve.

Open fixture's shutoff valves.

Turn faucets on and off to check their operation.

With the water running, check all water and waste joint connections for leaks.

With the fixture filled with water, check operation of drain plug.

Make any repairs or adjustments at once

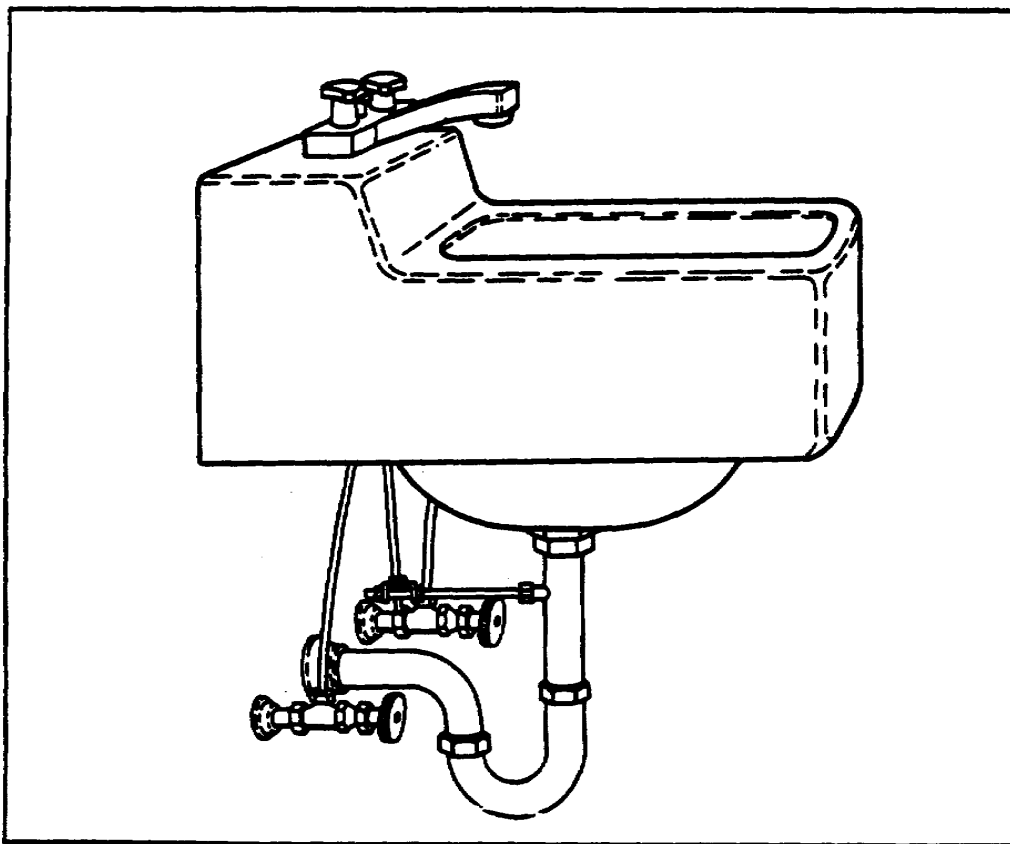

**FIGURE 17. TESTING FOR MECHANICAL OPERATION AND LEAKS**

**Lesson 1/Learning Event 8**

**Learning Event 8  
SELF-CHECK EXERCISE**

Fill in the blanks with your responses.

When you install a new lavatory or sink, check for \_\_\_\_\_ and \_\_\_\_\_.

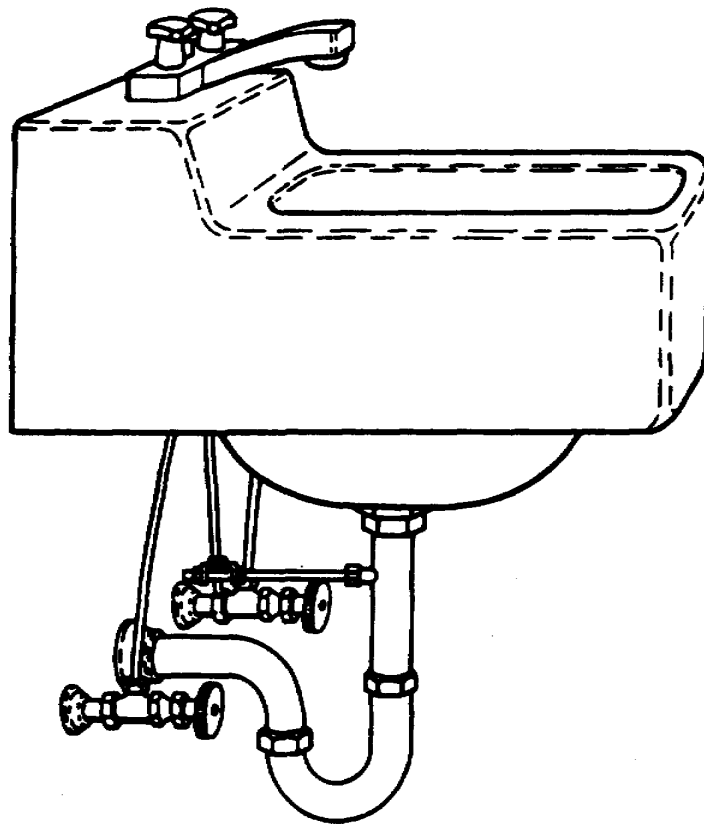

**SELF-CHECK EXERCISE SOLUTIONS**

Mechanical operation,, leaks

**Lesson 1**  
**REVIEW EXERCISE**

Check your understanding of Lesson 1 by completing this review exercise. Try to complete all of the questions without looking back at the lesson. When you are finished turn to the solutions at the end of the exercise and check your responses. If you missed any, go back and restudy the place in the lesson where the information is given.

1. What is this type of lavatory called?
  - A. Trough
  - B. Self-rimmed
  - C. Wall-hung
  - D. Pedestal

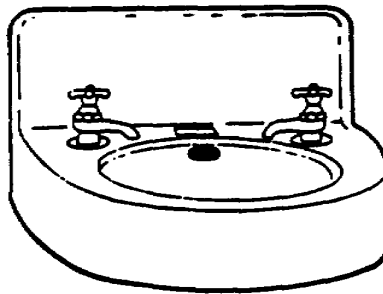

2. What is this type of sink called?
  - A. Scullery
  - B. Pedestal
  - C. Single-compartment
  - D. Slop

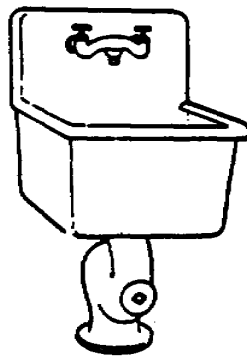

Solutions for this exercise are on page 36.

Lesson 1/Review Exercise

3. Which illustration, A or B, shows a mounting board installed correctly?

A.

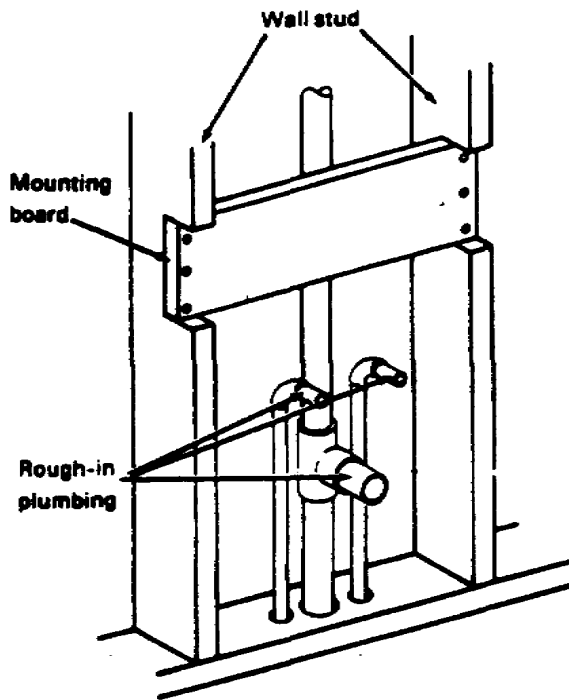

B.

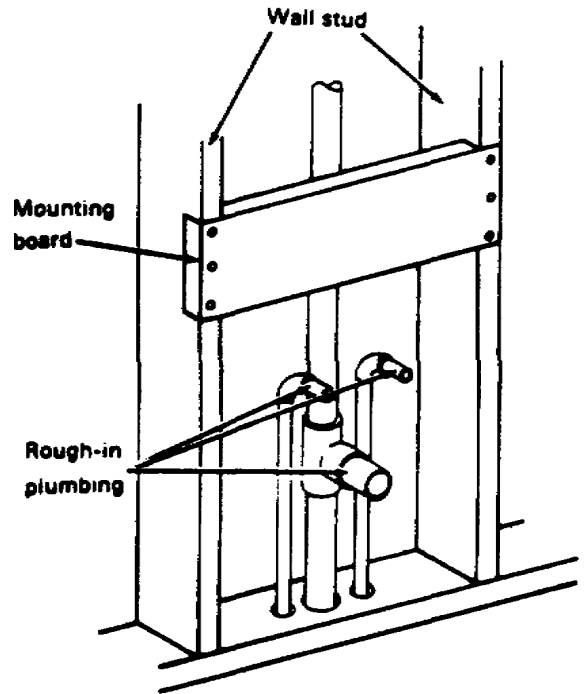

Fill in the blanks with your responses.

4. A mounting bracket installed at the correct height from the floor must be \_\_\_\_\_.
5. The lavatory must be \_\_\_\_\_ when placed on the mounting bracket.
6. Plumber's putty is applied to the \_\_\_\_\_ of a single faucet before setting it in place on a lavatory.

Solutions for this exercise are on page 36.

7. Match items underneath the lavatory in the correct order of installation.

- A. Metal washer
- B. Tailpiece
- C. Rubber washer
- D. Locknut

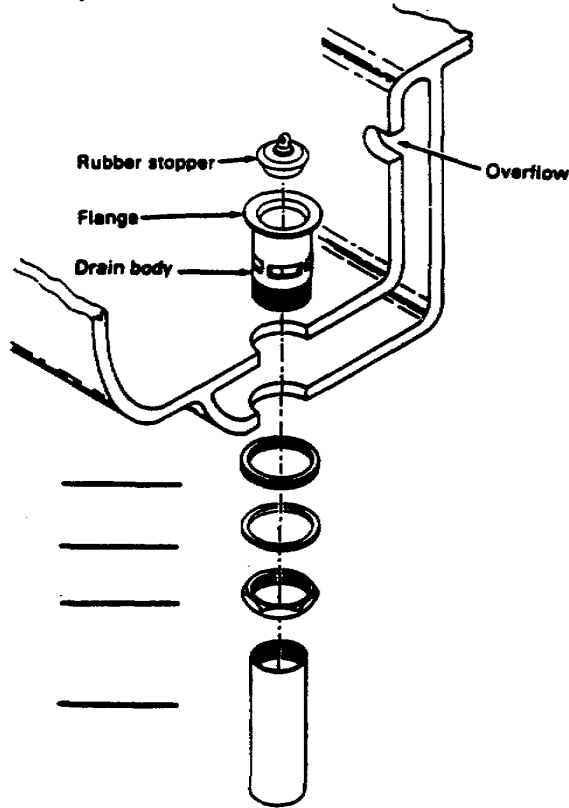

8. Match items underneath the sink in the correct order of installation.

- A. Metal washer
- B. Gasket
- C. Plastic sleeve
- D. Tailpiece
- E. Locknut
- F. Coupling nut

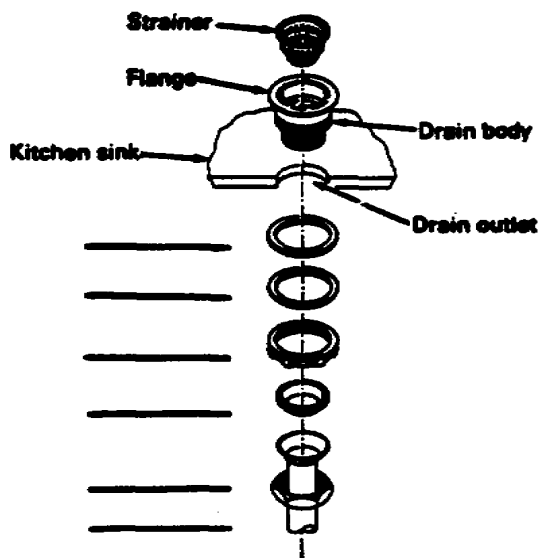

Solutions for this exercise are on page 36.

Lesson 1/Review Exercise

9. Identify each item required to install a P-trap.

- A. \_\_\_\_\_
- B. \_\_\_\_\_
- C. \_\_\_\_\_
- D. \_\_\_\_\_

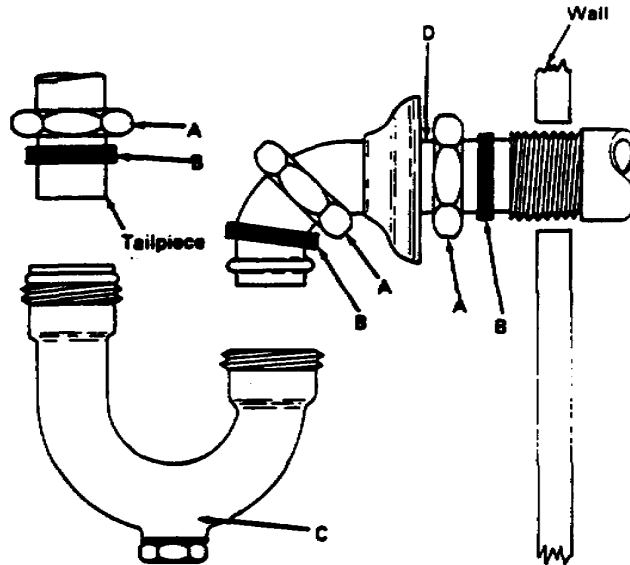

10. Which illustration, A or B, identifies an angle valve connection for rigid copper tubing?

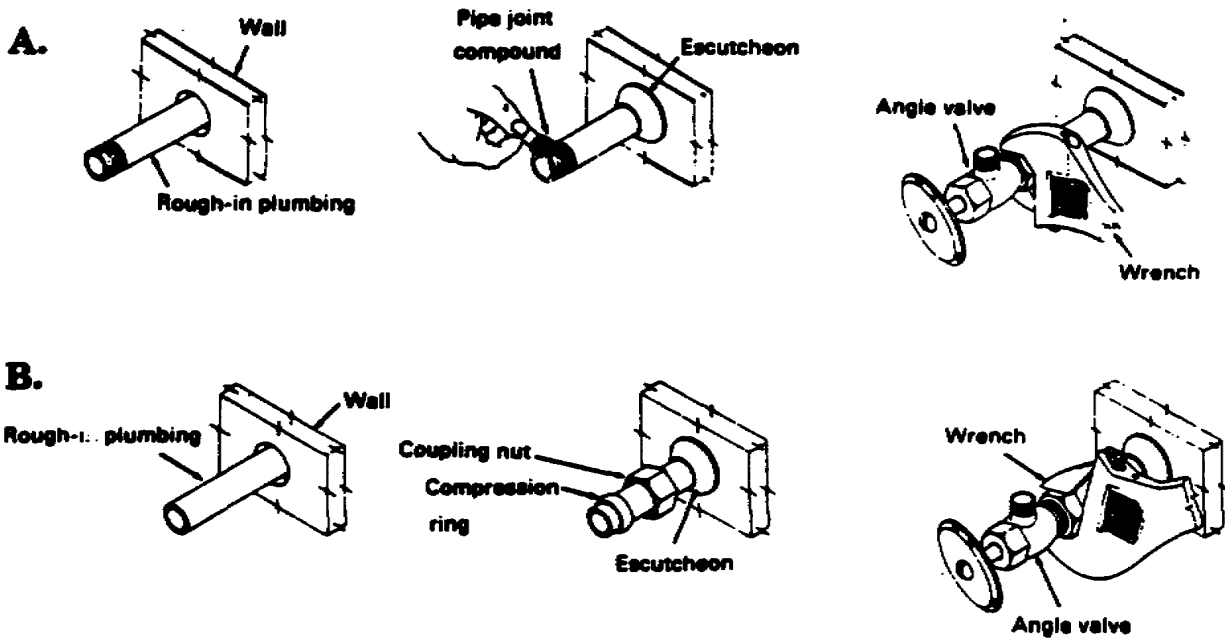

Solutions for this exercise are on page 36.



Fill in the blanks with your responses.

11. To connect a shutoff angle valve to rough-in plastic pipe, you need a \_\_\_\_\_.
12. A spring bender is used to \_\_\_\_\_ the tubing for a good fit between the valve and faucet threads.
13. Identify each item required to install a water service connection for a lavatory/sink.
  - A. \_\_\_\_\_
  - B. \_\_\_\_\_
  - C. \_\_\_\_\_
  - D. \_\_\_\_\_

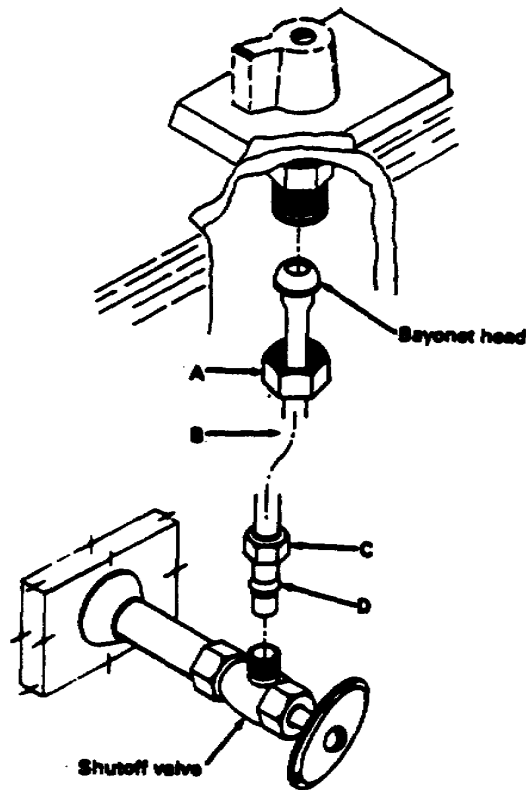

Solutions for this exercise are on page 36

REVIEW EXERCISE SOLUTIONS

1. C (Page 2)
2. D (Page 3)
3. B (Page 6)
4. Level (Page 7)
5. Level (Page 7)
6. Bottom or base (Page 10)
7. C (Page 12)
  - A
  - D
  - B
8. B (Page 14)
  - A
  - E
  - C
  - F
  - D
9. A Slip nut (Page 18)
  - B Washer
  - C Trap
  - D Drainpipe
10. B (Page 21)
11. Female adaptor (Page 22)
12. Bend (Page 26)
13. A Coupling nut (Page 27)
  - B Flexible tube connector
  - C Coupling nut ring
  - D Compression ring

**Lesson 2**  
**INSTALLATION OF WATER CLOSETS WITH**  
**FLUSHING DEVICES**

**OBJECTIVE**

At the end of this lesson, you will be able to describe the procedures used to install water closets with tanks.

**TASK**

Task No. 051-248-1009, Install water closet with tank.

**CONDITIONS**

Given subcourse booklet number EN5113 and an examination response sheet, you will work at your own pace and in your own selected environment with no supervision.

**STANDARDS**

Within approximately 4 hours, you should be able to study the lesson resources, answer the review exercises, and select the correct response to each examination question. You must respond correctly to 70 percent of the examination questions in order to receive credit for this subcourse.

**CREDIT HOURS**

4

**REFERENCES**

FM 5-51K

TM 5-551K

Lesson 2  
INSTALLATION OF WATER CLOSETS  
WITH FLUSHING DEVICES

Learning Event 1:  
IDENTIFYING WATER CLOSETS

A water closet is a water-flushed plumbing fixture designed to receive and dispose of human waste. The method of flushing can be with either a flush tank or a flushometer valve. Water closets are made of vitreous china, and they can be installed directly on the floor or wall (see Figures 18 and 19).

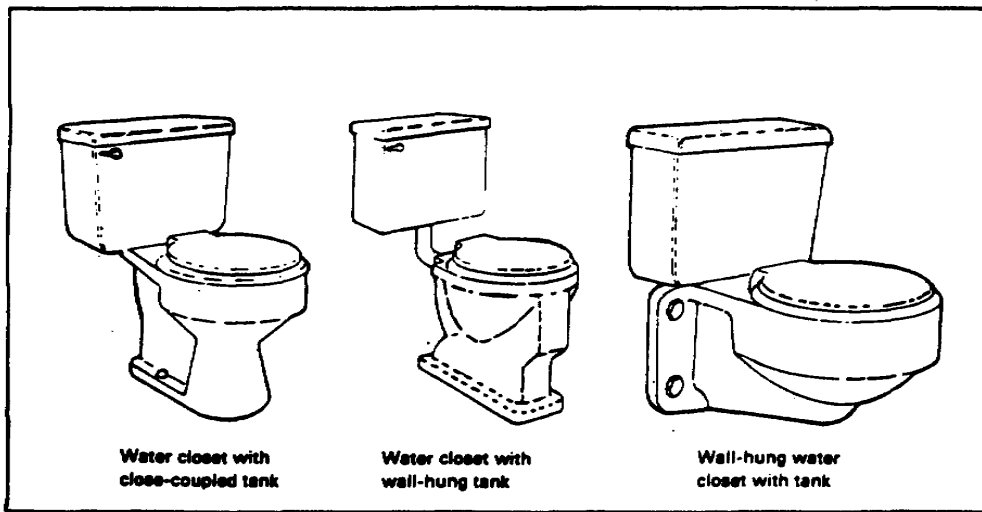

FIGURE 18. WATER CLOSETS WITH FLUSH TANKS

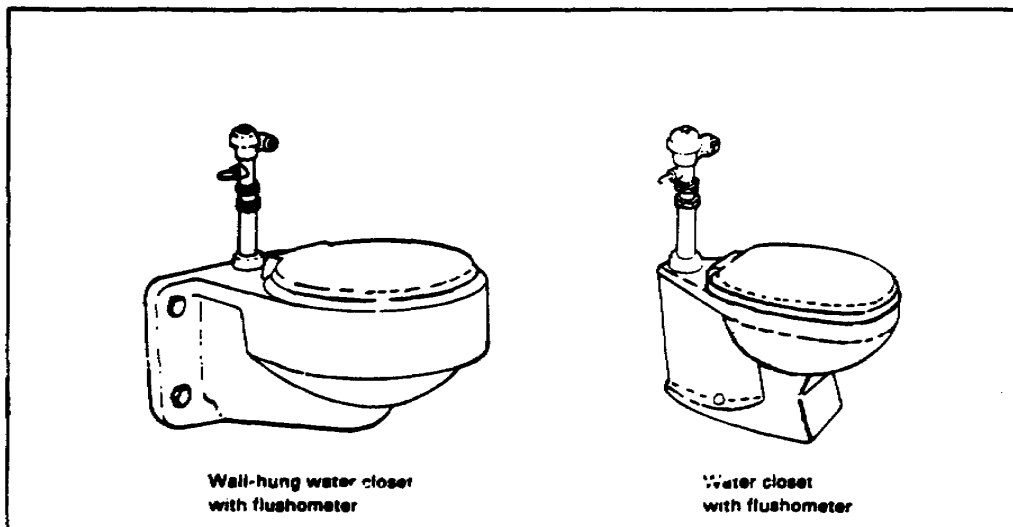
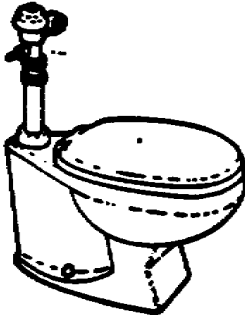
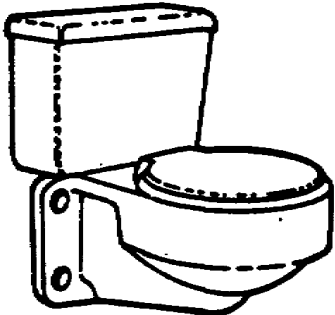
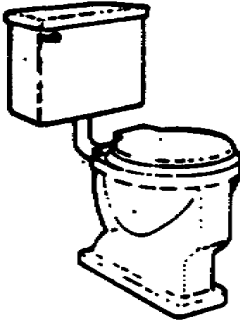
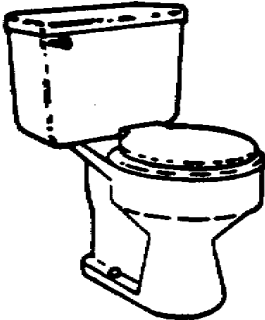

FIGURE 19. WATER CLOSETS WITH FLUSHOMETERS

**Learning Event 1**  
**SELF-CHECK EXERCISE**

Match each water closet with its description.

- A. Water closet with wall-hung tank
- B. Water closet with flushometer
- C. Water closet with close-coupled tank
- D. Wall-hung water closet with tank



**SELF-CHECK EXERCISE SOLUTIONS**

- C.
- A.
- D.
- B.

## Lesson 2/Learning Event 2

### Learning Event 2: INSTALLING WATER CLOSETS

The majority of water closets are installed using a closet flange, a bowl, and a flush tank or a flushometer valve. The flange is connected to the rough-in plumbing and secured to the floor, the bowl is attached to the flange, and the flush tank or flushometer is connected to the bowl. Finally, water service is connected to the tank.

**Installing a closet flange.** Use the following steps to install a closet flange (see Figure 20):

Slip the closet flange onto the closet bend, and make the joint connection for the type of piping used.

Secure the flange to the floor with fasteners.

Slip bowl hold-down bolts into the bowl slots of the flange.

The flange is now ready for the bowl.

#### NOTES:

1. Flange joint connection to closet bend can be for cast-iron, plastic, and copper piping.
2. Flange can be secured to wooden, concrete, and tile floors, using the proper type fasteners.

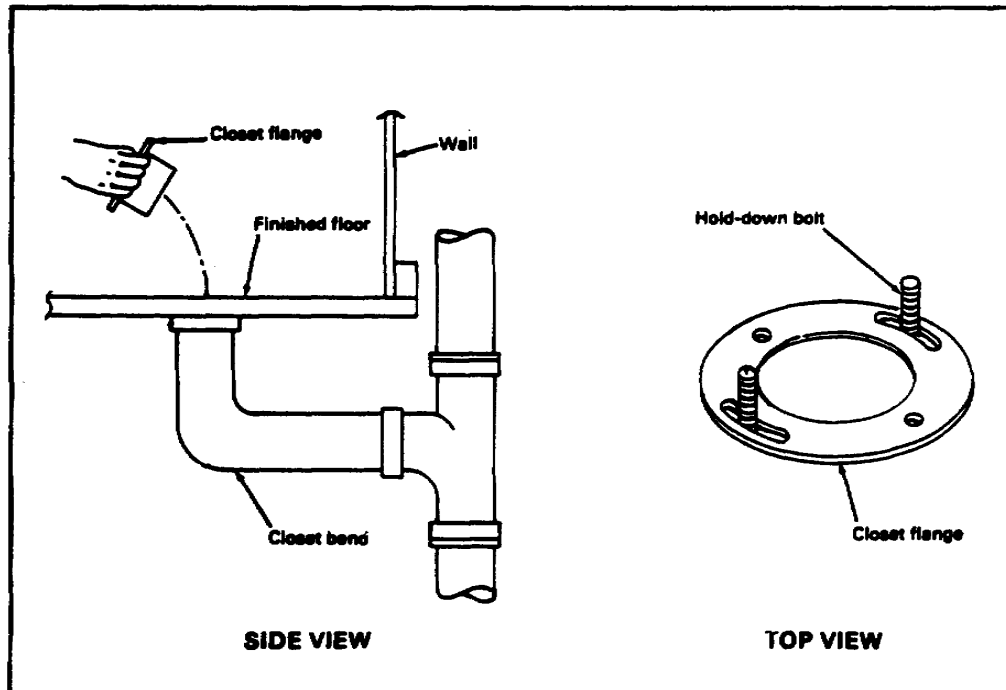

FIGURE 20. INSTALLING A CLOSET FLANGE

**Preparing a water closet bowl for installation.** Use the following steps to prepare the bowl for installation (see Figure 21):

Set the bowl upside down on paper to keep from scratching it.

Place the wax gasket evenly over the horn, with the tapered side against the bottom of the bowl.

Run a thick layer of putty around the base of the bowl.

The bowl is now ready to install.

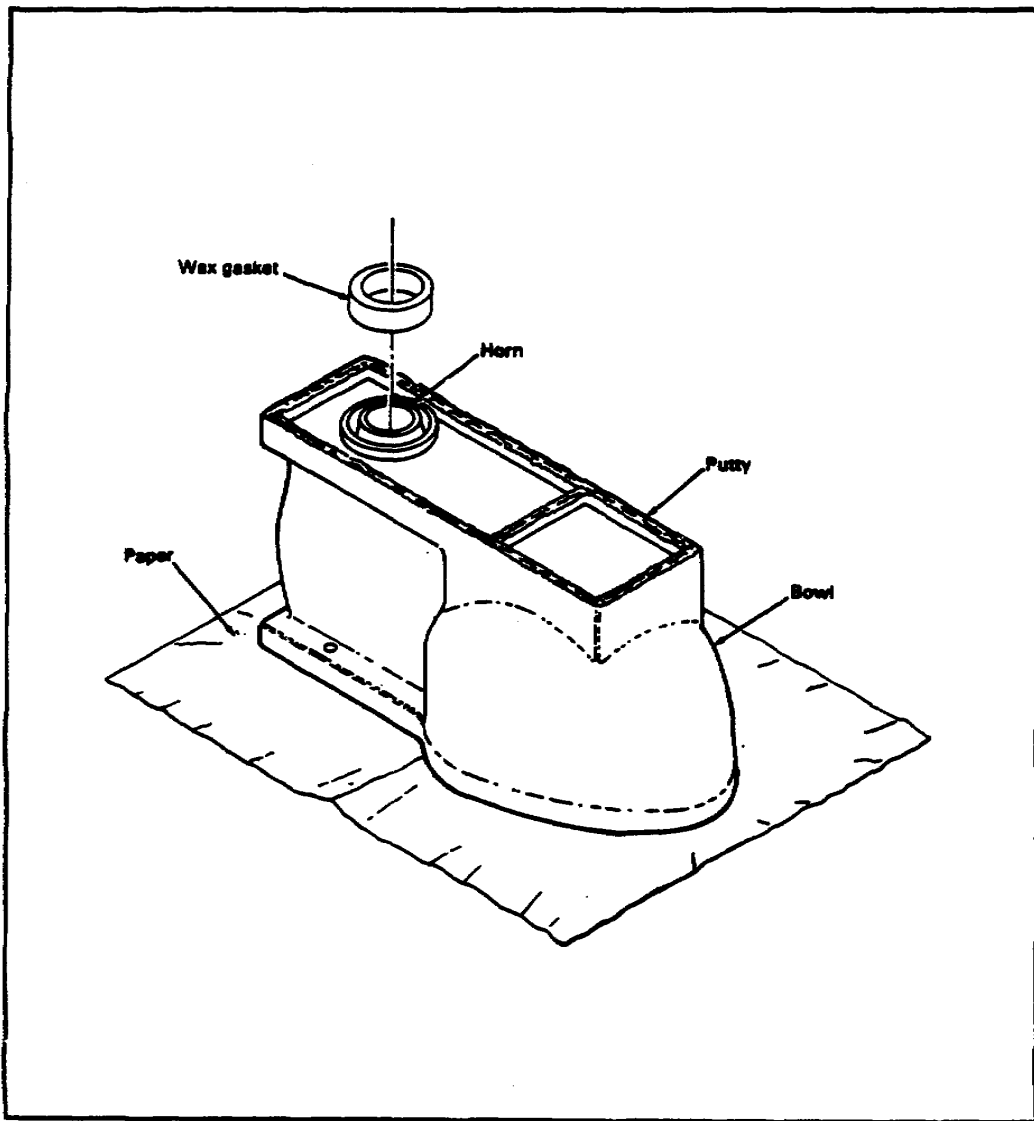

FIGURE 21. PREPARING CLOSET BOWL FOR INSTALLATION

## Lesson 2/Learning Event 2

**Installing a water closet bowl to the floor.** Use the following steps to install the bowl (see Figure 22):

Turn the bowl right side up, and place it so that the hold-down bolts pass through the bowl's bolt holes.

Slightly twist the bowl to smooth out the putty.

Firmly press down on the bowl to seat the wax gasket.

Place a washer over each bolt, and then fasten nuts on hand-tight.

Check to see if bowl is level. If it is, tighten nuts. If not, use thin metal shims until it is level, and then tighten nuts.

Snap bolt cap on.

**NOTE: Do not overtighten the nuts, as this will cause the bowl to crack.**

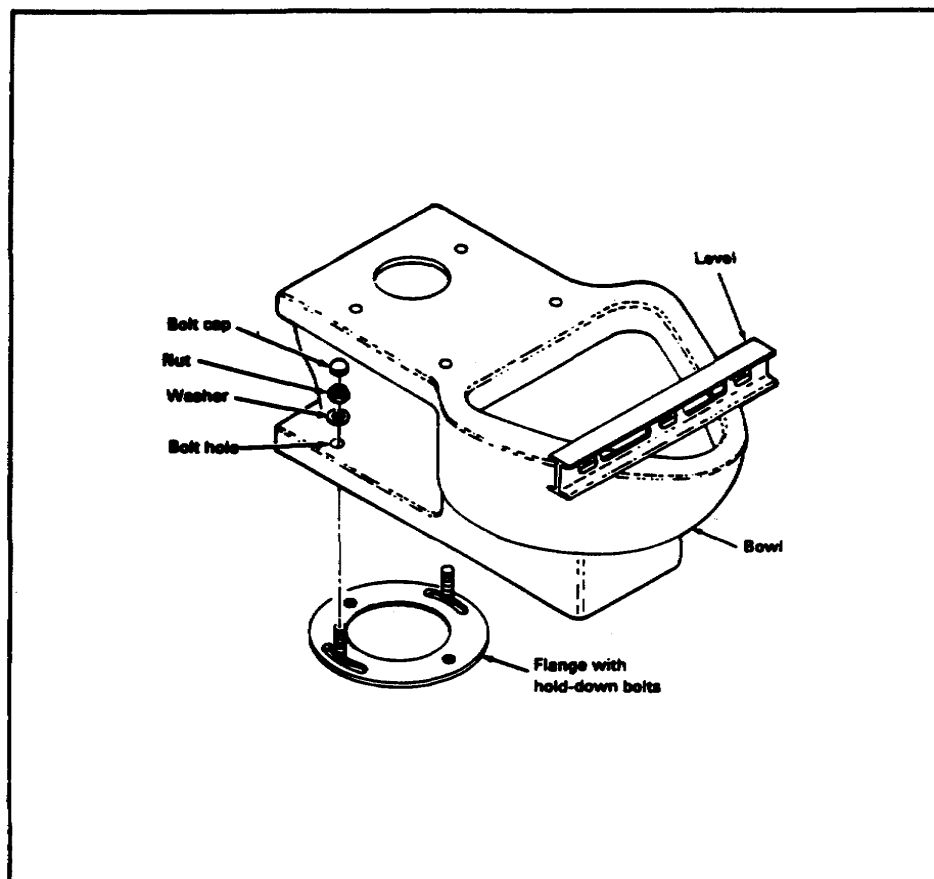

**FIGURE 22. INSTALLING WATER CLOSET BOWL TO FLOOR**



**Installing a water closet bowl to the wall.** Use the following steps to install a wall-hung closet bowl (see Figure 23):

Following manufacturer's instructions, install a carrier body and connect it to the rough-in plumbing.

Install sealing gasket into opening at rear of closet bowl.

Carefully pick up bowl, and set it against the wall so that the carrier's bolts pass through the bowl's holes on both sides.

Slide washer over each of the four bolts, and fasten nuts hand-tight to bolt.

Use a carpenter's level to make sure bowl is level.

Tighten all nuts with a wrench and snap over nuts.

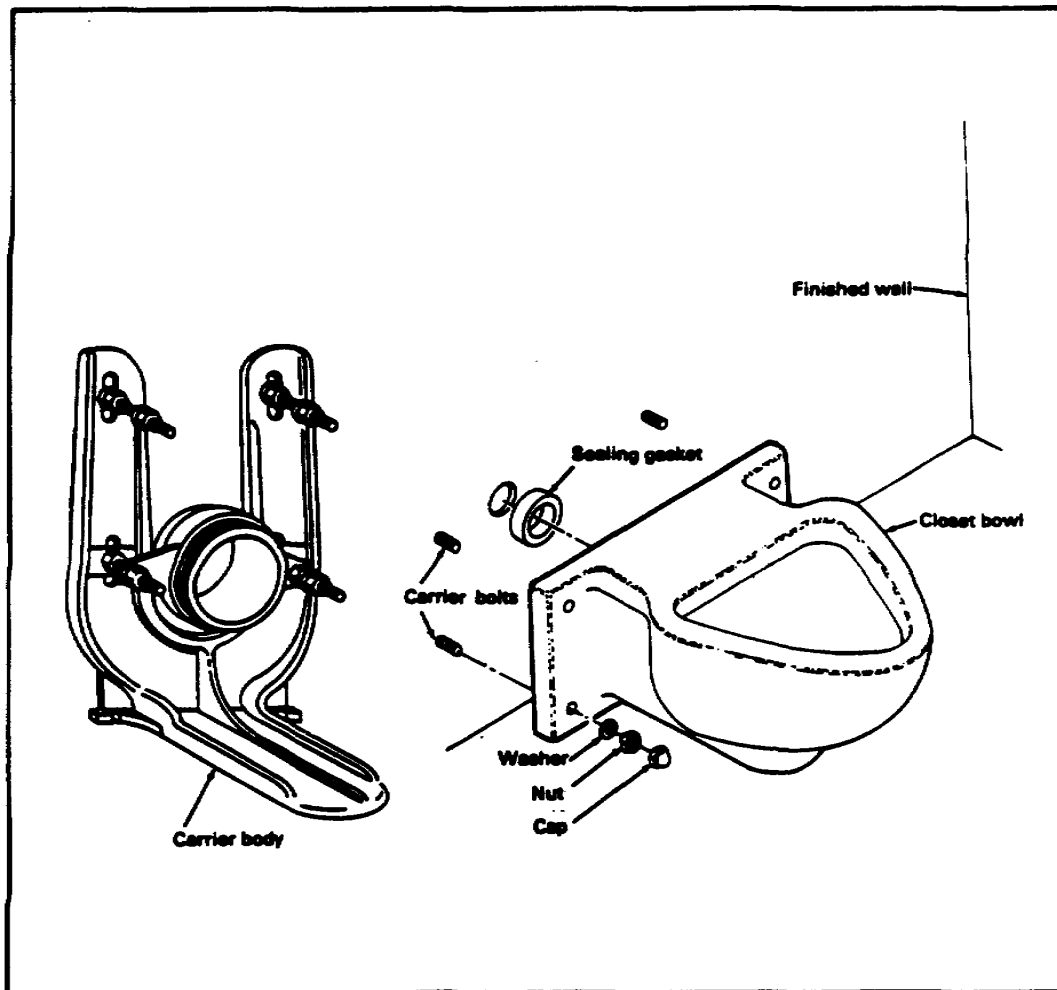

FIGURE 23. INSTALLING WATER CLOSET BOWL TO WALL

## Lesson 2/Learning Event 2

### Learning Event 2 SELF-CHECK EXERCISE

Fill in the blanks.

1. After the closet flange is secured to the finished floor, the bowl \_\_\_\_\_ are slipped in place.
2. A wax gasket is pressed evenly over the \_\_\_\_\_ on the bottom of the bowl.
3. A thick layer of \_\_\_\_\_ is placed around the \_\_\_\_\_ on the bottom of the bowl.
4. The bowl is twisted slightly to \_\_\_\_\_ out the \_\_\_\_\_.
5. To seat the wax gasket, push down \_\_\_\_\_ on the \_\_\_\_\_.
6. The bowl must be \_\_\_\_\_ for proper installation.
7. A wall-hung closet bowl requires a \_\_\_\_\_ to install it against a wall.

### SELF-CHECK EXERCISE SOLUTIONS

1. Hold-down bolts
2. Horn
3. Putty, base
4. Smooth, putty
5. Firmly, bowl
6. Level
7. Carrier body

### Learning Event 3: ATTACHING FLUSHING DEVICES

The flushing device for a water closet may be a flush tank or a flushometer. The flush tank is attached to the closet bowl or is wall-hung. The flushometer is attached to the closet bowl with a short vertical pipe. A flush tank has an assorted group of parts. These parts are connected in the tank, following the manufacturer's instructions, to form a flushing mechanism.

***Attaching a close-coupled flush tank onto a closet bowl.*** Use the following steps to attach a flush tank to closet bowl (see Figure 24):

Push cone-shaped gasket onto tank outlet.

With bolt holes lined up, place tank on bowl.

Slip a rubber washer on each bolt and, from inside the tank, place the bolts with washers through the holes.

At the bowl, slide washer onto bolt, and fasten the nut to the bolt on each side.

Tighten nuts with a wrench to seat cone-shaped gasket and tank on bowl.

**NOTE:** A close-coupled flush tank is attached to a wall-hung closet bowl in the same manner.

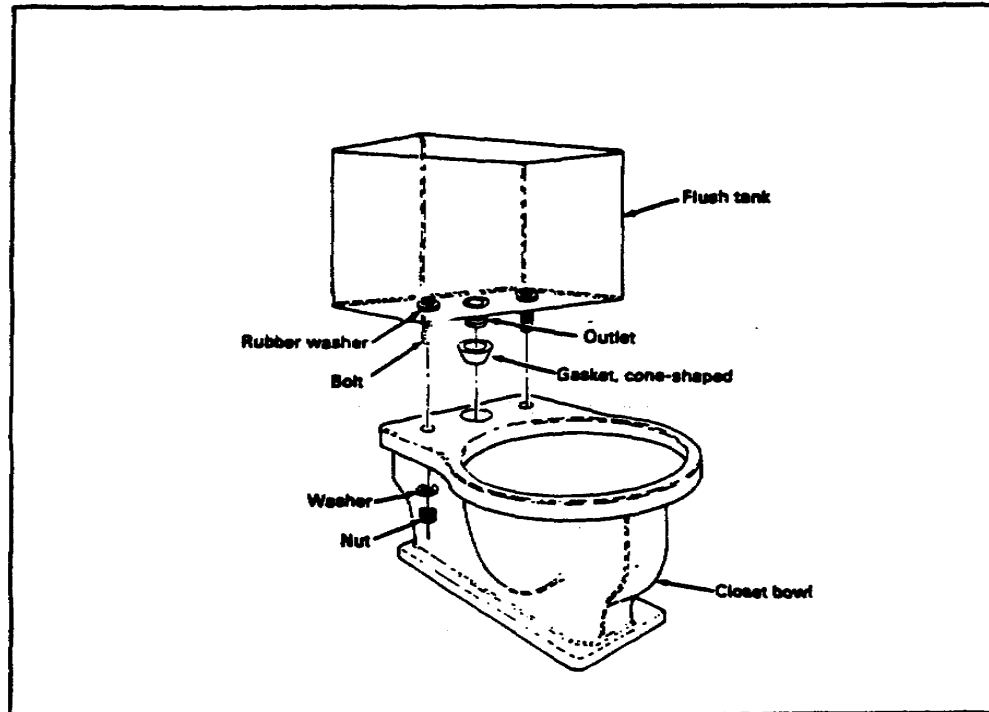

**FIGURE 24. ATTACHING A CLOSE-COUPLED FLUSH TANK**

## Lesson 2/Learning Event 3

**Connecting a wall-hung tank to the closet bowl.** Use the following steps to install a wall-hung flush tank to rear of closet bowl (see Figure 25):

- Install mounting board, using recommended height from manufacturer's instructions.
- Install tank outlet connection and spud connection, following manufacturer's instructions.
- Slide spud flange and rubber washer onto threaded spud.
- Slide slip-joint nut and then metal friction ring onto closet elbow for hookup to spud.
- Place end of elbow against spud, and fasten slip-joint nut hand-tight onto spud.
- Slide rubber washer onto tank outlet connection.
- Slide slip-joint nut and metal friction ring onto closet elbow for hookup to tank outlet.
- Fasten slip-joint nut hand-tight to tank's outlet connection.
- Attach tank to wall with screw bolts. Make sure tank is level and lined up with bowl.
- Tighten slip-joint nuts with wrench.

**NOTE:** Always make map to bowl connection using the manufacturer's instructions.

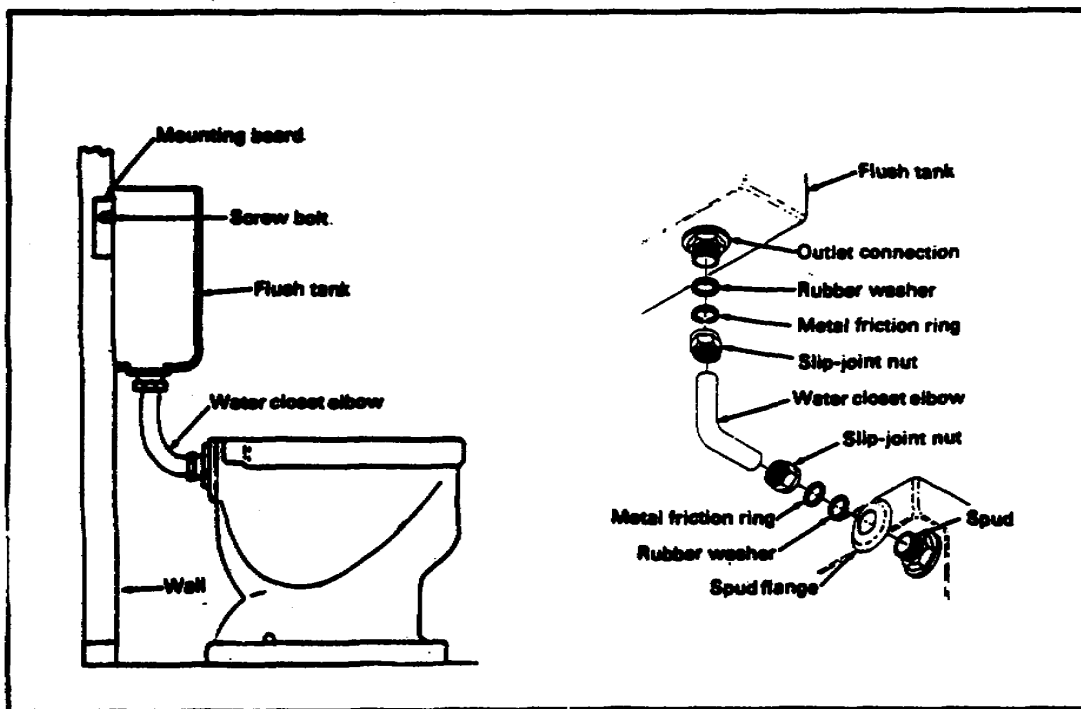

FIGURE 25. CONNECTING A WALL-HUNG TANK TO CLOSET BOWL

**Lesson 2/Learning Event 3**

**Learning Event 3**

**SELF-CHECK EXERCISE**

1. Using the letters A through E, list in the steps in the correct order to install the flush tank to the closet bowl.

A. With bolt holes lined up, place tank on bowl.

B. At the bowl, slide washer onto bolt, and fasten the nut onto the bolt on each side.

C. Push cone-shaped gasket onto tank outlet.

D. Slip a rubber washer on each bolt, and from inside the tank, place the bolts with washers through the holes.

E. Tighten nuts with a wrench to seat cone-shaped gasket and tank on bowl.

---

---

---

---

---

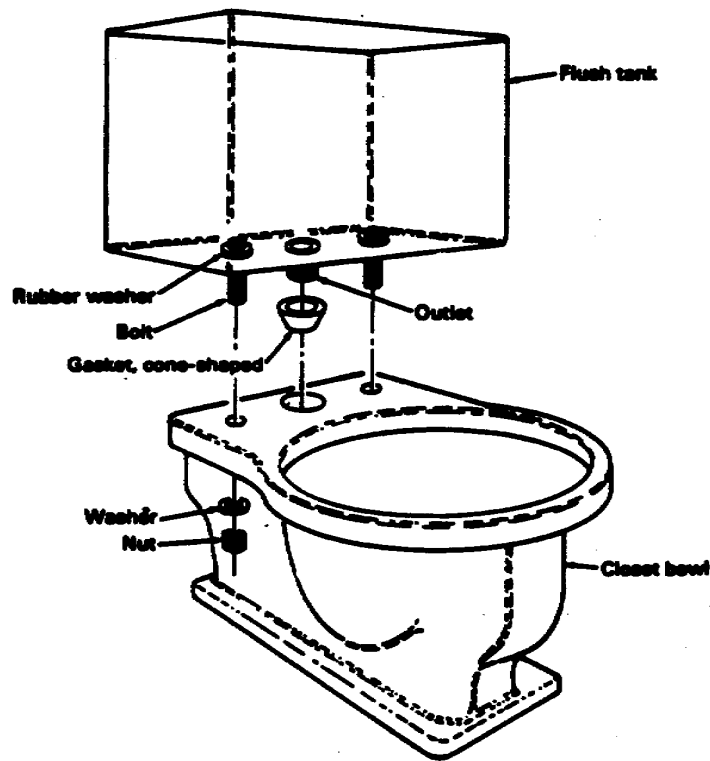

Solutions for this exercise are from 49.

**Lesson 2/Learning Event 3**

2. Using the letters A through J, list the steps in the correct order to install a wall-mount flush tank with connections to closet bowl.

- A. Slide rubber washer onto tank outlet connection.
- B. Attach tank to wall with screw bolts. Make sure tank is level and lined up with bowl.
- C. Place end of elbow against spud, and fasten slip-joint nut and hand-tight onto spud.
- D. Using recommended height from manufacturer's instructions, install mounting board.
- E. Install tank outlet connection and spud connection, following manufacturer's instructions.
- F. Fasten slip-joint nut to tank's outlet connections.
- G. Tighten slip-joint nuts with wrench.
- H. Slide slip-joint nut and then metal friction ring onto closet elbow for hookup to spud.
- I. Slide spud flange and rubber washer onto threaded spud.
- J. Slide slip-joint nut and then metal friction ring onto closet elbow for hookup to tank outlet.

---

---

---

---

---

---

---

---

---

---

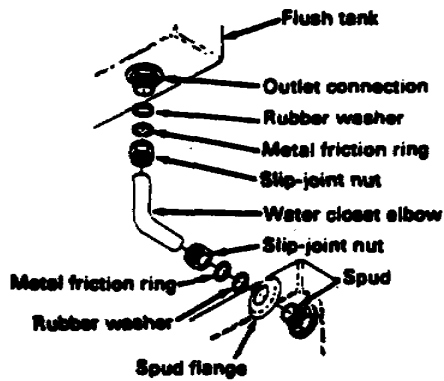
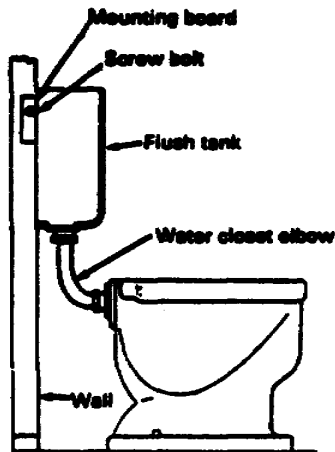

Solutions for this exercise are on page 49.

**SELF-CHECK EXERCISE SOLUTIONS**

1. C  
A  
D  
B  
E
2. D  
E  
I  
H  
C  
A  
J  
F  
B  
G

**Learning Event 4:  
INSTALLING FLUSHING MECHANISMS**

A flush tank comes with an assortment of parts for its flushing mechanism. When these parts are connected, they form a mechanical flushing mechanism. Since there are several types of flushing mechanisms, always follow the manufacturer's instructions to install them (see Figure 26).

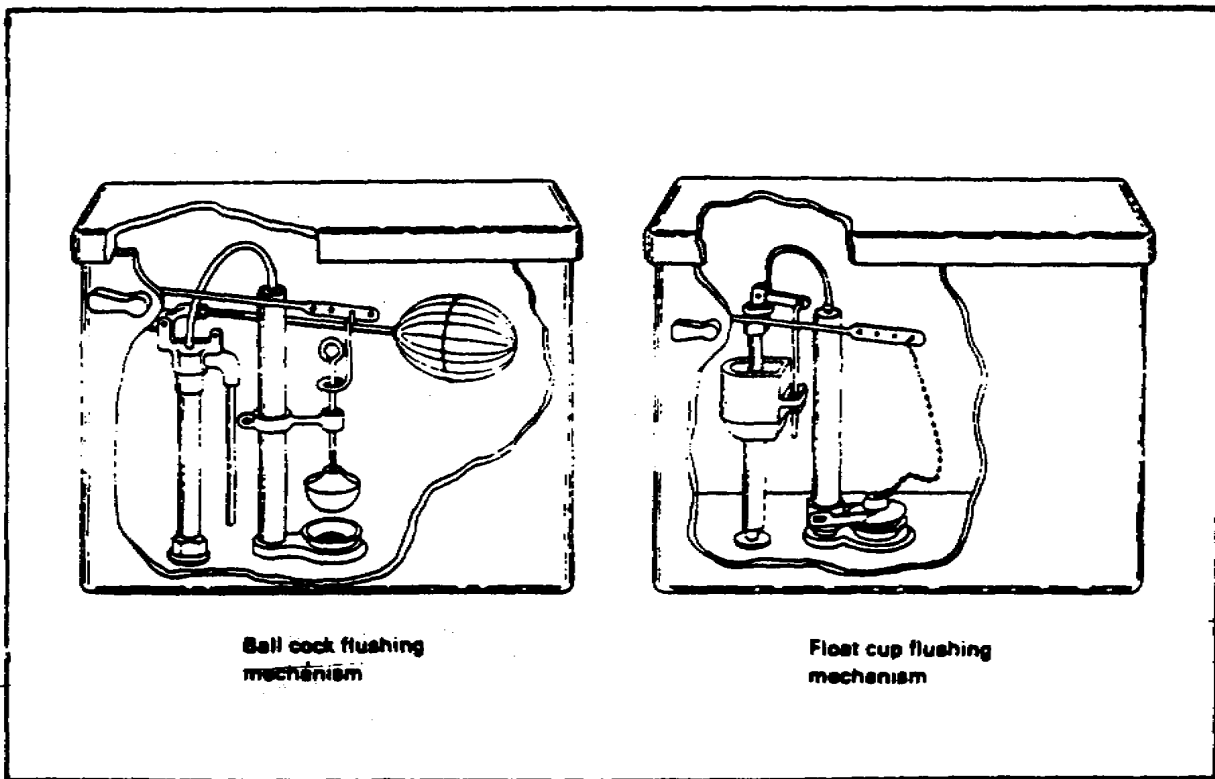

**FIGURE 26. COMMON FLUSHING MECHANISMS**

*Installing a ball cock flushing mechanism.* Use the following steps to install a ball cock flushing mechanism (see Figure 27):

- Connect Douglas valve to tank's drain outlet.
- Screw overflow pipe onto Douglas valve, if not attached.
- Slide guide holder onto overflow pipe about halfway down, and tighten holder screw.
- Install ball cock assembly into hole at left bottom of tank; then tighten locknut under tank.
- Screw float rod into ball cock, and then screw ball float to other end of rod.



Attach overflow tube to ball cock and to overflow pipe.

Install operating handle with trip arm, and tighten handle's locknut.

Slide lift wire through loop of connecting wire.

Slide lift wire through guide holder, and screw flush ball onto threaded end of lift wire.

Attach connecting wire to trip arm.

**NOTE:** All adjustments are made on the flushing mechanism after water supply is connected.

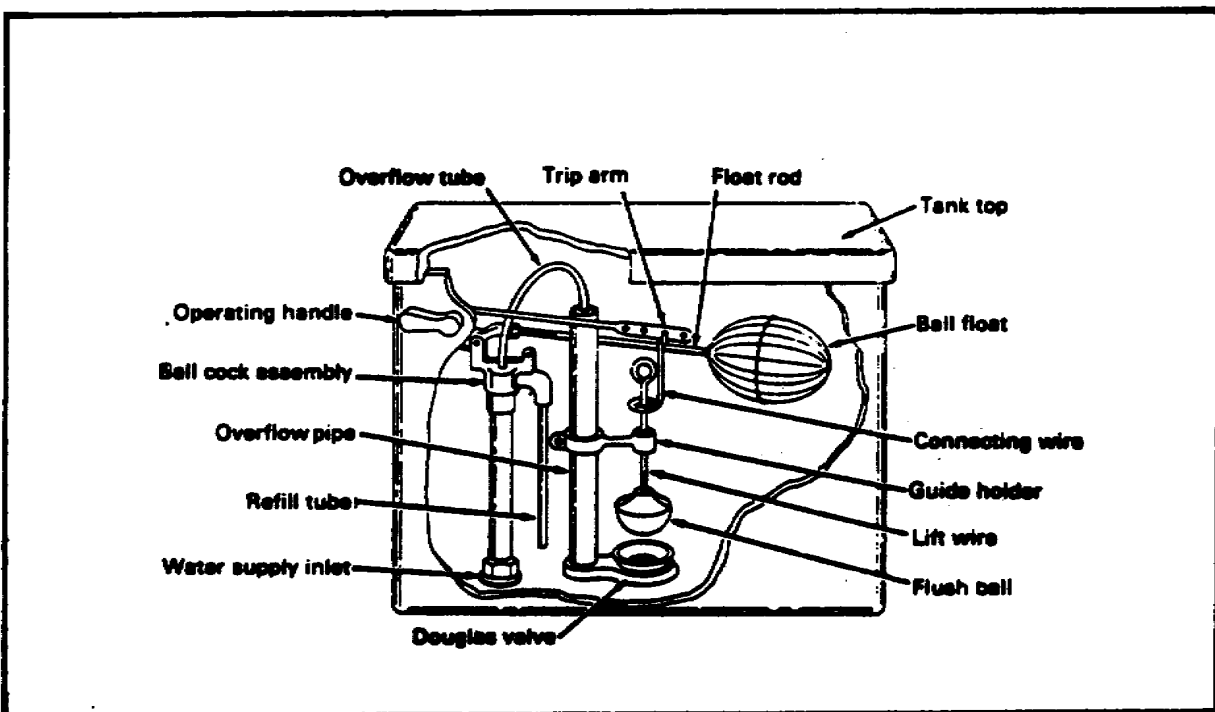

FIGURE 27. INSTALLING BALL COCK FLUSHING MECHANISM

## Lesson 2/Learning Event 4

***Installing a plastic cup flushing mechanism.*** Use the following steps to install a plastic float cup flushing mechanism (see Figure 28):

Connect Douglas valve to tank's drain outlet.

Screw overflow pipe onto Douglas valve, if not attached.

Install float cup assembly into hole at left bottom of tank, and then tighten locknut under tank.

Slide guide holder with flapper ball onto the overflow pipe, and push it to the bottom of the overflow pipe.

Connect overflow tube to the float cup assembly and to the overflow pipe.

Install operating handle with trip arm, and tighten handle's locknut.

Connect chain to trip arm and flapper ball.

**NOTE:** All adjustments are made to the flushing mechanism after water supply is connected.

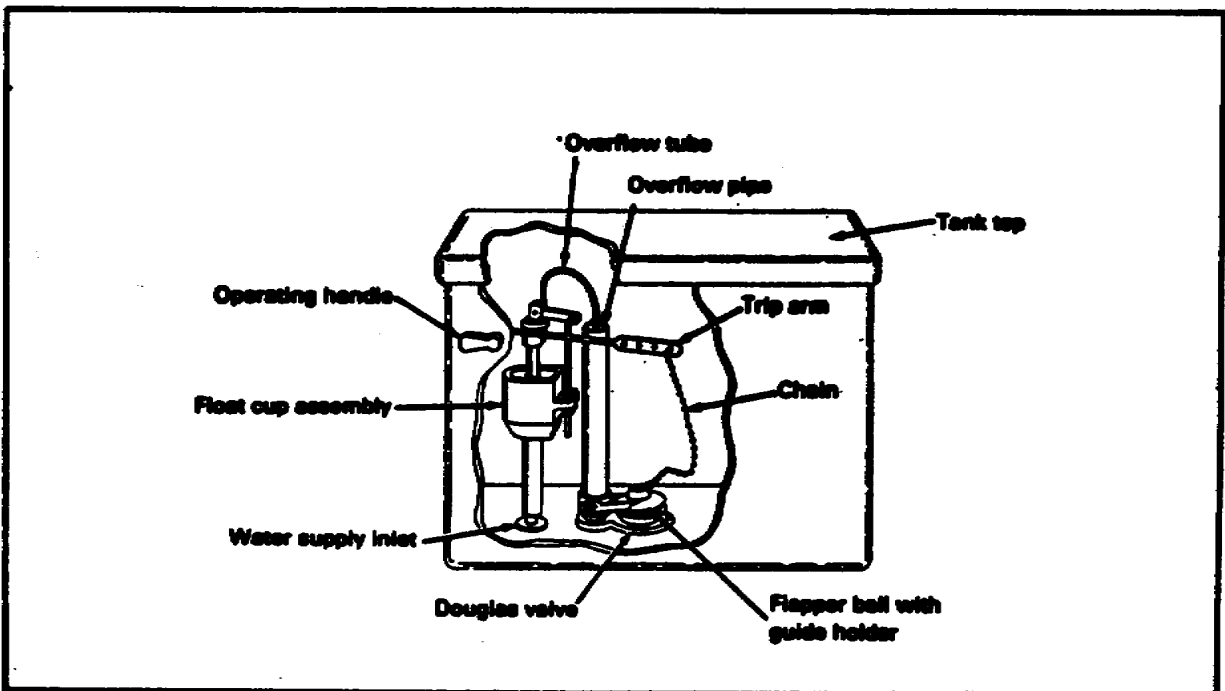

**FIGURE 28. INSTALLING PLASTIC CUP FLUSHING MECHANISM**

**Learning Event 4**  
**SELF-CHECK EXERCISE**

1. Identify the type of flushing mechanisms.

- A. \_\_\_\_\_
- B. \_\_\_\_\_

A.

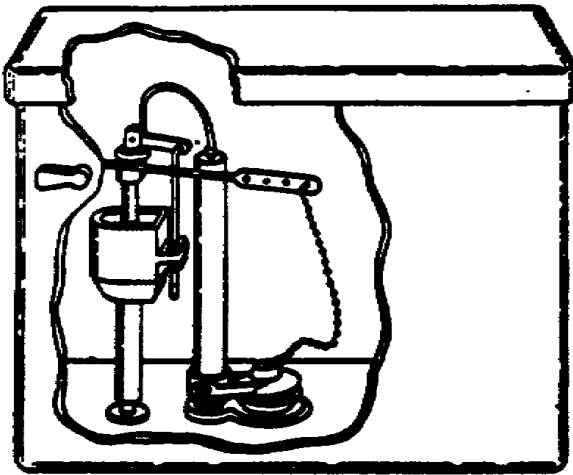

B.

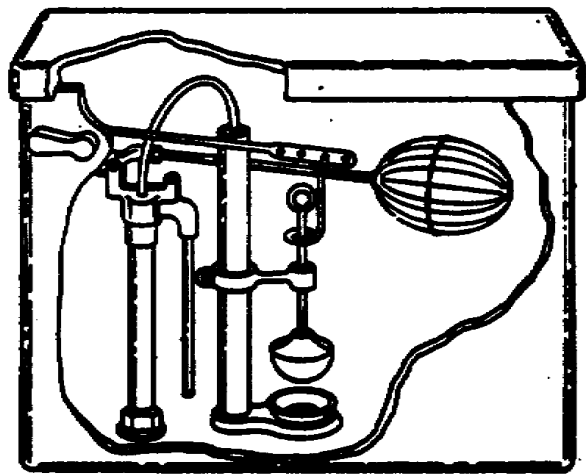

**SELF-CHECK EXERCISE SOLUTIONS**

- 1. A. Float (plastic) cup
- B. Ball cock

**Lesson 2/Learning Event 4**

2. Using the letters A through J, list the steps in the correct order to install a ball cock flushing mechanism.

- A. Screw float rod into ball cock, and then screw ball float to other end of rod.
- B. Attach overflow tube to ball cock and to overflow pipe.
- C. Install operating handle with trip arm, and tighten handle's locknut.
- D. Slide lift wire through loop of connecting wire.
- E. Slide the wire through guide holder, and screw flush ball onto threaded end of lift wire.
- F. Install ball cock assembly into hole at left bottom of tank, and then tighten locknut under tank.
- G. Slide guide holder onto overflow pipe about halfway down, and tighten holder screw.
- H. Connect Douglas valve tank's drain outlet.
- I. Attach connecting wire to trip arm.
- J. Screw overflow pipe onto Douglas valve if not attached.

---

---

---

---

---

---

---

---

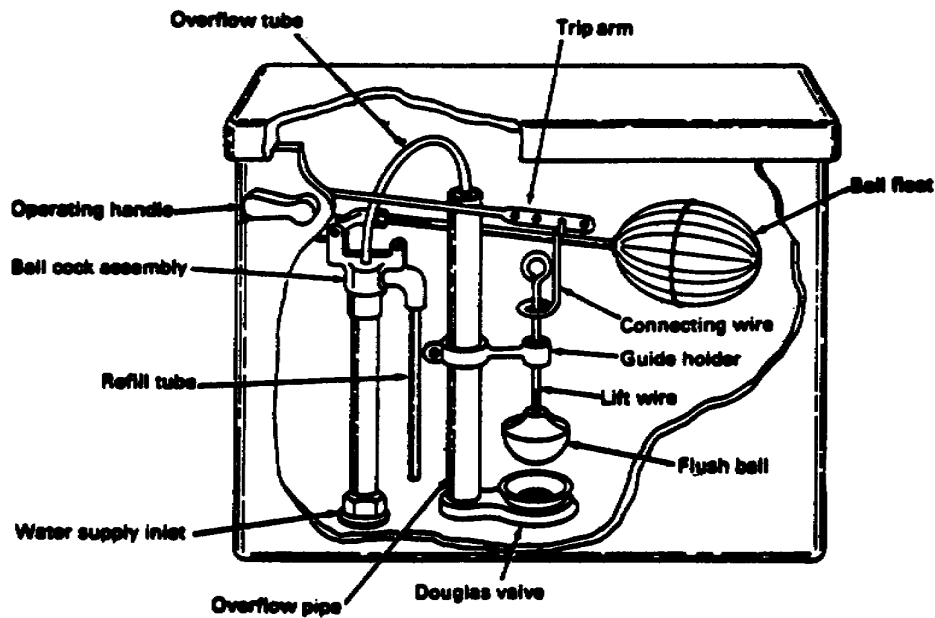

Solutions for this exercise are on page 55.

3. Using the letters A through G, list the steps in the correct order to install a float cup flushing mechanism.

- A. Slide guide holder with flapper ball onto the overflow pipe. Push it to the bottom of the overflow pipe.
- B. Connect overflow tube to the float cup assembly and to the overflow pipe.
- C. Connect Douglas valve to tank's drain outlet.
- D. Screw overflow pipe onto Douglas valve, if not attached.
- E. Install float cup assembly into hole at left bottom of tank, and then tighten locknut under tank.
- F. Install operating handle with trip arm, and tighten handle's locknut.
- G. Connect chain to trip arm and flapper ball.

---

---

---

---

---

---

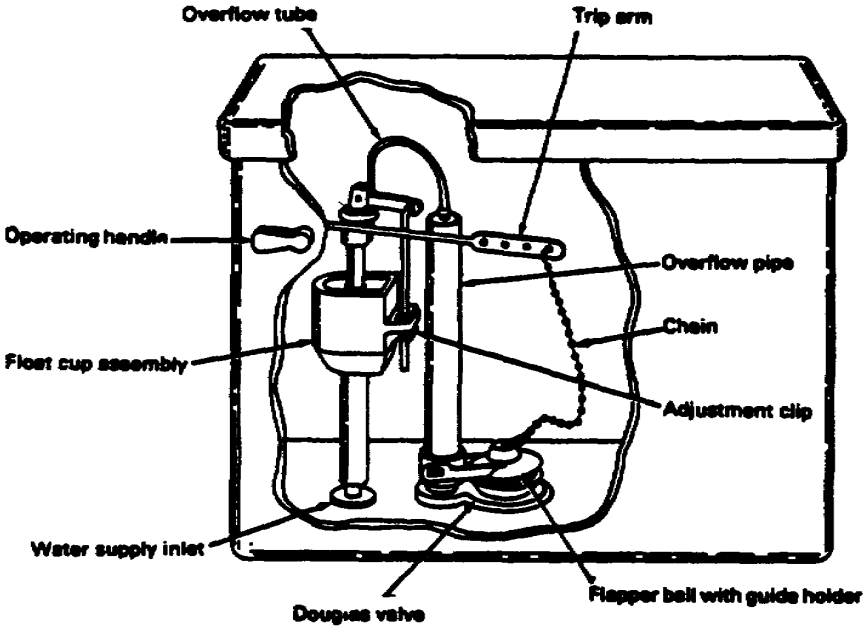

SELF-CHECK EXERCISE SOLUTIONS

- 2. H, J, G, F, A, B, C, D, E, I
- 3. C, D, E, A, B, F, G

## Lesson 2/Learning Event 5

### Learning Event 5: INSTALLING FLUSHOMETER

A flushometer is a valve that discharges a preset amount of water to flush a water closet. The flushometer can be either a diaphragm or a piston type of valve. The upper part of the flushometer connected to a water supply line fitting at the wall, and the lower part is connected to the top rear of the water closet bowl (see Figure 29).

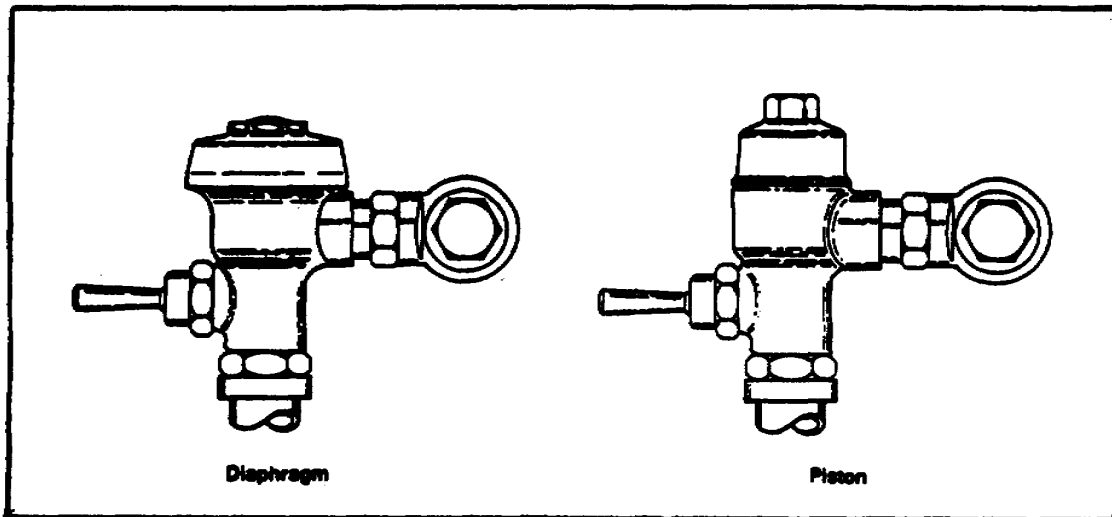

FIGURE 29. FLUSHOMETERS

**NOTE:** The following plumbing hardware should come with a flushometer for installation:

- Spud coupling for closet bowl connection
- Spud coupling for water pipe connection
- Chrome flanges for wall and bowl

*Installing a flushometer.* Use the manufacturer's rough-in dimensions and instructions to install a flushometer. Once installed, turn on water supply and adjust flushometer valve's water flow. The following illustrations are examples of manufacturer's rough-in dimensions and instructions (see Figure 30):

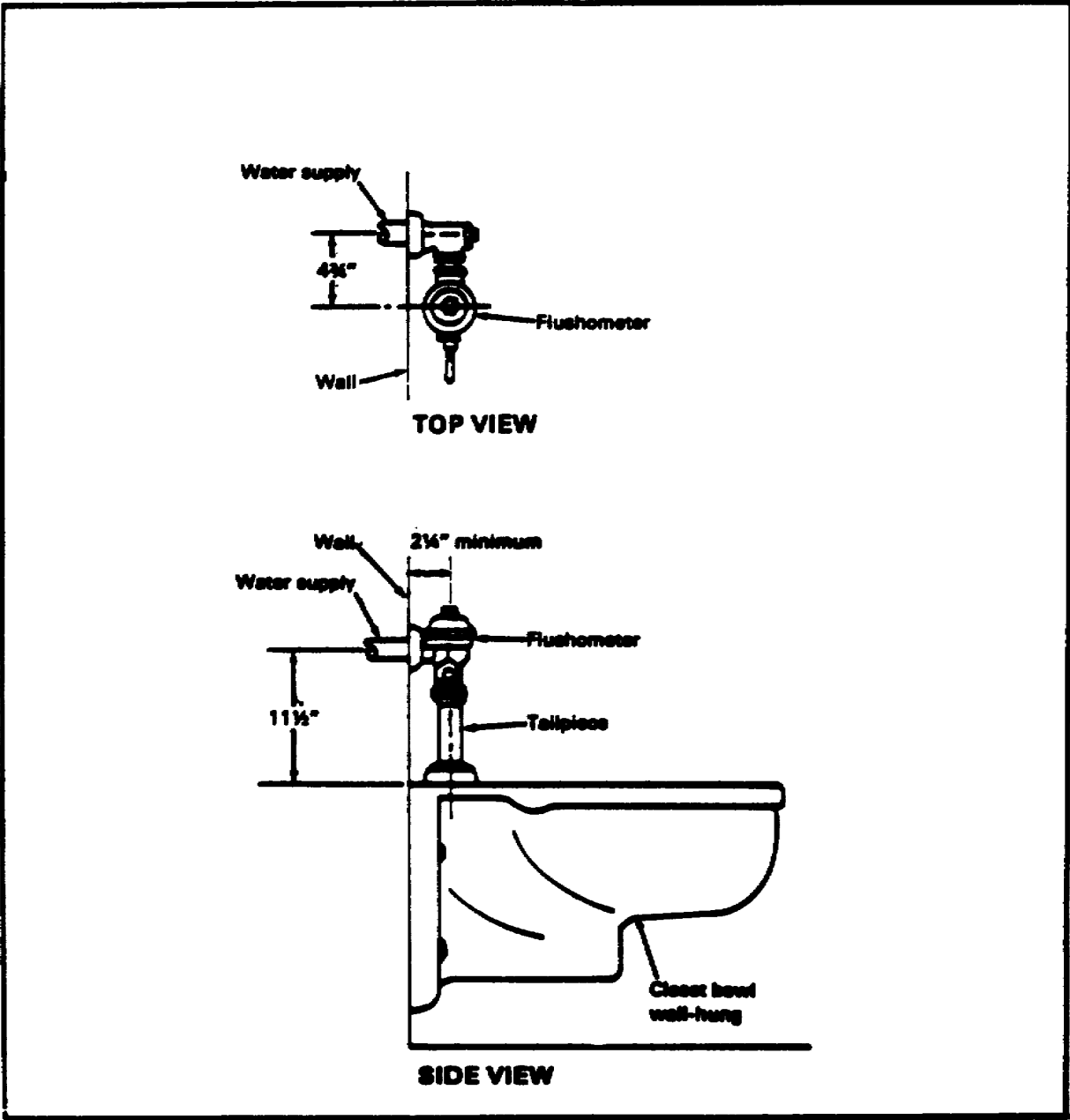

FIGURE 30. INSTALLING A FLUSHOMETER

Lesson 2/Learning Event 5

**Learning Event 5**  
**SELF-CHECK EXERCISE**

1. Identify each type of flushometer.

A. \_\_\_\_\_

B. \_\_\_\_\_

A.

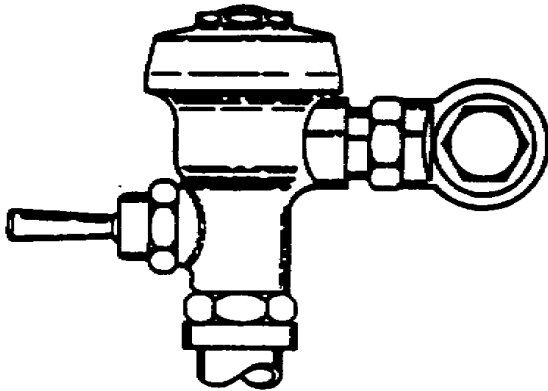

B.

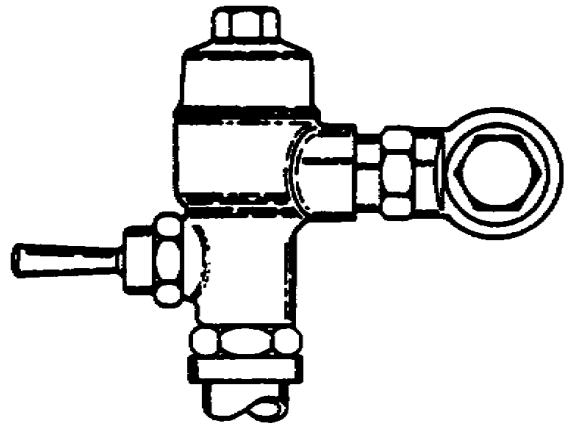

Fill in the blanks.

2. A flushometer is installed using the \_\_\_\_\_ instructions.

3. The flushometer valve water flow is preset after \_\_\_\_\_.

**SELF-CHECK EXERCISE SOLUTIONS**

1. A. Diaphragm  
B. Piston
2. Manufacturer's
3. Installation



## Lesson 2/Learning Event 6

### Learning Event 6: INSTALLING WATER SERVICE

A water closet tank requires cold water supply service for flushing. The water supply is connected from the rough-in plumbing to a shutoff valve and from the shutoff valve to the tank's inlet.

**Installing water service to a water closet tank.** Use the following steps to install water service to a water closet tank (see Figure 31):

Slide escutcheon onto pipe, and push it against the wall.

Attach shutoff angle valve, making the proper connection for the type of pipe used. Make sure connection is tight and valve's other opening points straight up to tank.

With a spring bender, bend the flexible tube connector to a fitting position.

Slide tank connection coupling nut, valve connection coupling nut, and compression ring, in that order, onto the flexible tube connector.

Attach coupling nut to shutoff valve and tighten.

Attach coupling nut to tank inlet and tighten.

Set shutoff valve in closed position.

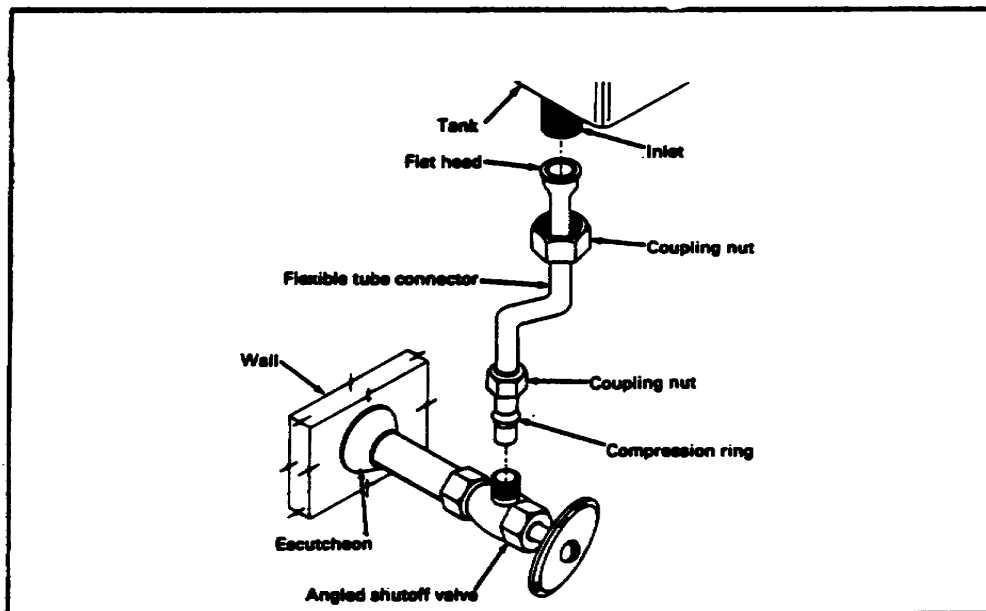

FIGURE 31. INSTALLING WATER SERVICE TO WATER CLOSET TANK

**Installing water service through floor.** Use a straight shutoff valve when the water service pipe comes up through the floor.

**Learning Event 6**  
**SELF-CHECK EXERCISE**

Using the letters A through G, list the steps in the correct order to install water closet tank.

- A. Slide tank connection coupling nut, valve connection coupling nut, and compression ring, in that order, onto the flexible tube connector.
- B. Slide escutcheon onto pipe, and push it against the wall.
- C. Attach shutoff angle valve, making the proper connection for the type of pipe used. Make sure connection is tight and valve's other opening points straight to tank.
- D. With a spring bender, bend the flexible tube connector to a fitting position.
- E. Attach coupling nut to shutoff valve and tighten.
- F. Attach coupling nut to tank inlet and tighten.
- G. Set shutoff valve in close position.

---

---

---

---

---

---

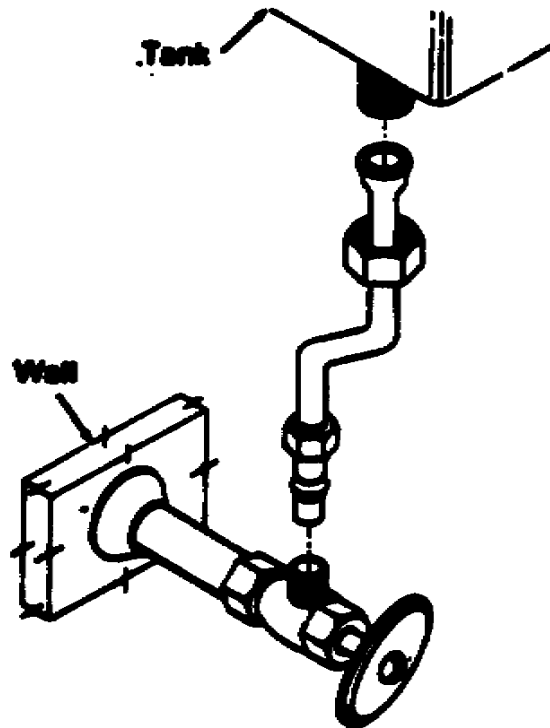

**SELF-CHECK EXERCISE SOLUTIONS**

B, C, D, A, E, F, G

### Learning Event 7: ADJUSTING FLUSHING MECHANISMS

The water closet is now installed with water and water connections. Turn on water supply, and open shutoff valve for water flow into the flush tank. Flush the tank several times to check the height of the water level in the flush tank. The water level should be about 1 inch below the top of the overflow pipe.

*Adjustments for ball cock type flushing mechanism.* Use the following steps to adjust a ball cock type flushing mechanism (see Figure 32):

For incomplete or erratic flushing, adjust handle and trip arm, connecting wire, lift wire, guide holder, and flush ball.

Adjust water level by bending the ball float rod.

After adjustments are made, flush the tank several times, observing operation.

Then place top on flush tank.

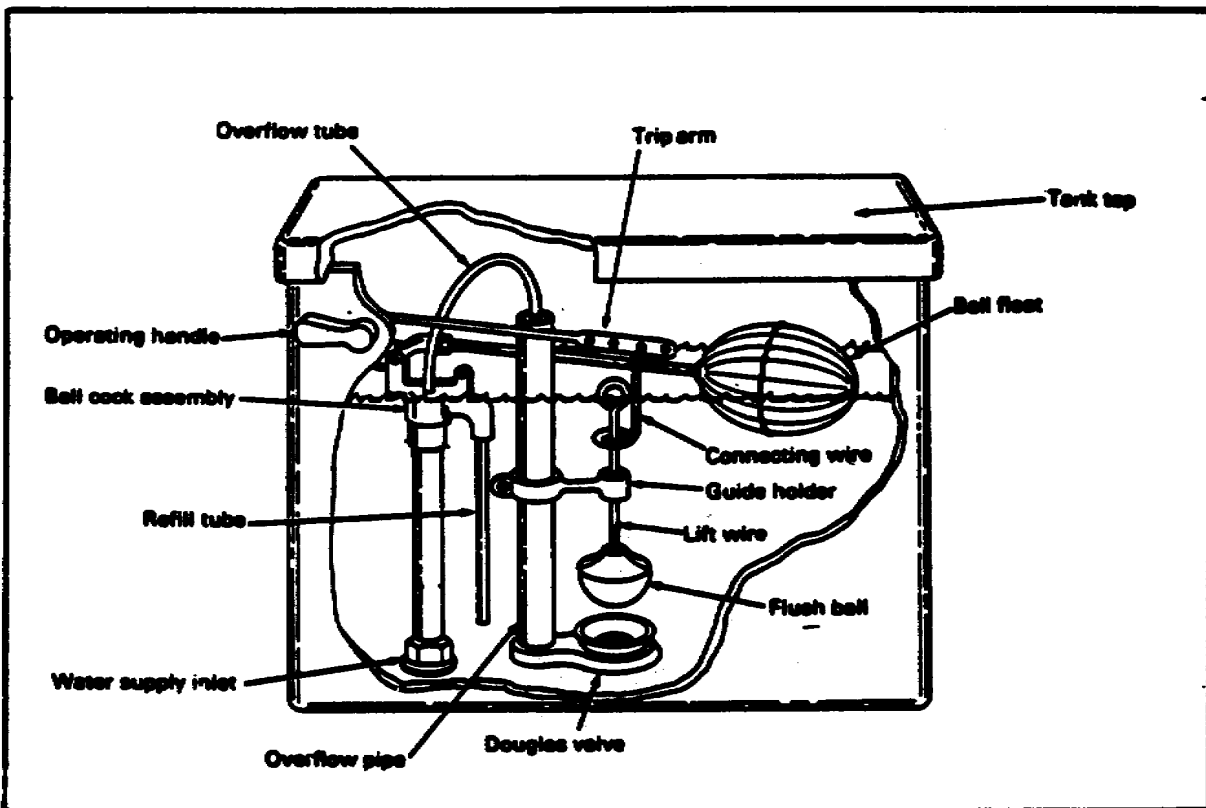

FIGURE 32. ADJUSTING BALL COCK MECHANISM

## Lesson 2/Learning Event 7

**Adjustments for a plastic float cup flushing mechanism.** Use the following steps to adjust a plastic float cup flushing mechanism (see Figure 33):

For incomplete or erratic flushing, adjust handle and tip arm, chain, and flapper ball with guide holder.

Adjust water level by moving adjustment clip up or down on the pull rod.

After adjustments are made, flush the tank several times, observing operation.

Then place top on flush tank.

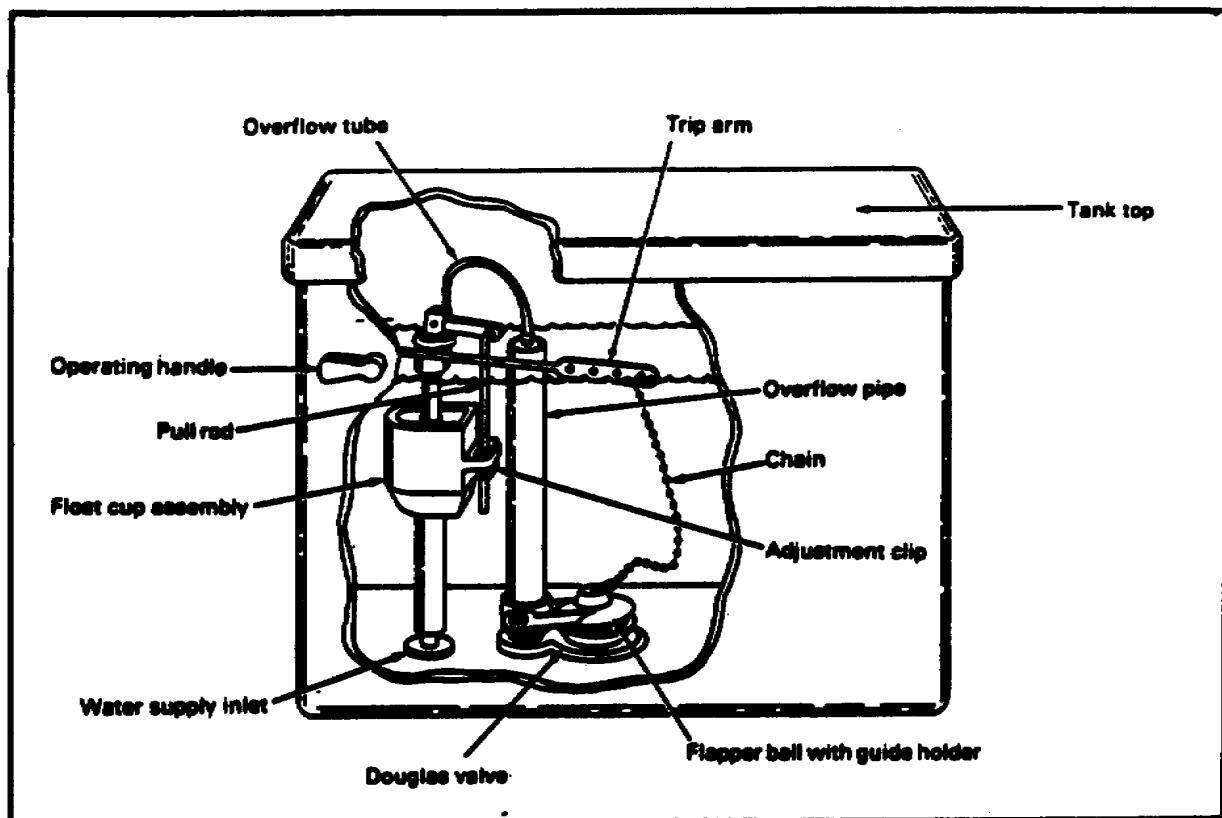

FIGURE 33. ADJUSTING PLASTIC FLOAT CUP MECHANISM

**Learning Event 7**  
**SELF-CHECK EXERCISE**

Fill in the blanks.

1. Flush the tank several times to check the height of the \_\_\_\_\_ in the flush tank.
2. The water level in the flush tank should be about \_\_\_\_\_ below the top of the overflow pipe.
3. The water level on a ball cock type flushing mechanism is adjusted by \_\_\_\_\_ the ball float rod.
4. The water level on a plastic float cup type flushing mechanism is adjusted by moving the \_\_\_\_\_ up down on the pull rod.

**SELF-CHECK EXERCISE SOLUTIONS**

1. Water level
2. 1 inch
3. Bending
4. Adjustment clip

## Lesson 2/Learning Event 8

### Learning Event 8 INSTALLING THE SEATS

The last item to be installed on a water closet is the seat. The seat is connected to the water closet bowl with washers and locknuts.

*Installing the seat.* Use the following steps to install the seat (see Figure 34):

Set seat's bolts through bowl's holes.

Slide washer over bolts, and screw locknuts on hand-tight.

Line up seat on bowl, and tighten locknuts with a wrench.

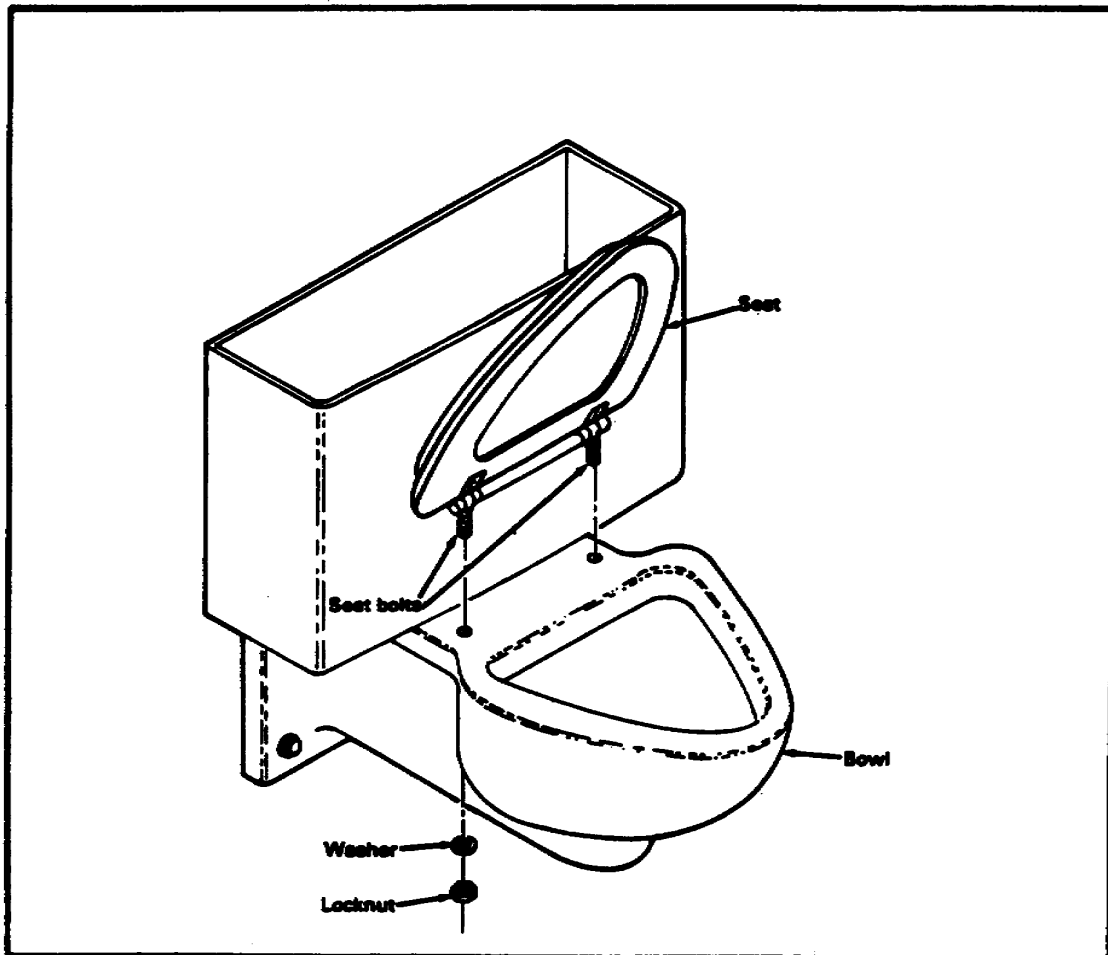

FIGURE 34. INSTALLING WATER CLOSET SEAT

**Learning Event 8**  
**SELF-CHECK EXERCISE**

Fill in the blanks with your responses.

The seat is connected to the water closet with \_\_\_\_\_ and \_\_\_\_\_.

**SELF-CHECK EXERCISE SOLUTIONS**

Washers, locknuts

## Lesson 2/Review Exercise

### Lesson 2 REVIEW EXERCISE

Check your understanding of Lesson 2 by completing this review exercise. Try to complete all of the questions without looking back at the lesson. When you are finished, turn to the solutions at the end of the lesson and check your responses. If you missed any, go back and restudy the place in the lesson where the information is given.

1. Identify the two types of water closets with flush tanks.

- A. \_\_\_\_\_
- B. \_\_\_\_\_

A.

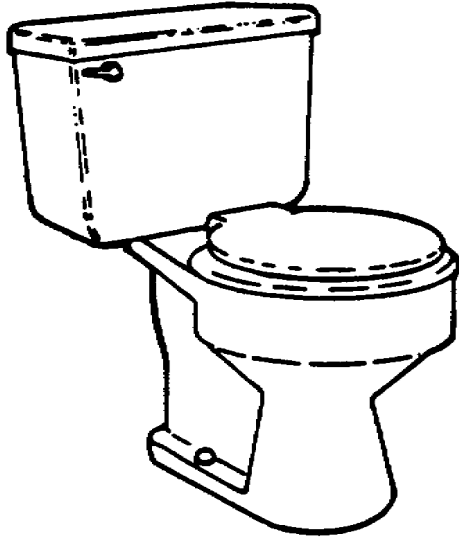

B.

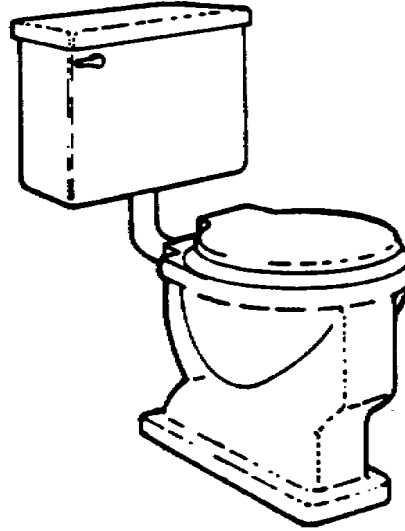

2. What is placed on a finished floor for installing a water closet?

- A. Closet bend
- B. Closet bowl
- C. Closet flange
- D. Closet bolts

3. A wax gasket is pressed evenly over the \_\_\_\_\_ on the bottom of the closet bowl.

4. A thick layer of putty is placed around the outer \_\_\_\_\_ on the bottom of the closet bowl.

5. When the closet bowl is bolted onto the flange, it must be \_\_\_\_\_.

Solutions for this exercise are on page 71.



6. Using the letters A through E, list the steps in the correct order to install a close-coupled flush tank to the bowl.

A. At the bowl, slide washer onto bolt, and fasten the nut onto the bolt on each side.

B. Tighten nuts with a wrench to seat cone-shaped gasket and tank on bowl.

C. Slip a rubber washer on each bolt and, from inside the tank, place the bolts with washers through the holes.

D. Push cone-shaped gasket onto tank outlet.

E. With bolt holes lined up, place tank on bowl.

---

---

---

---

---

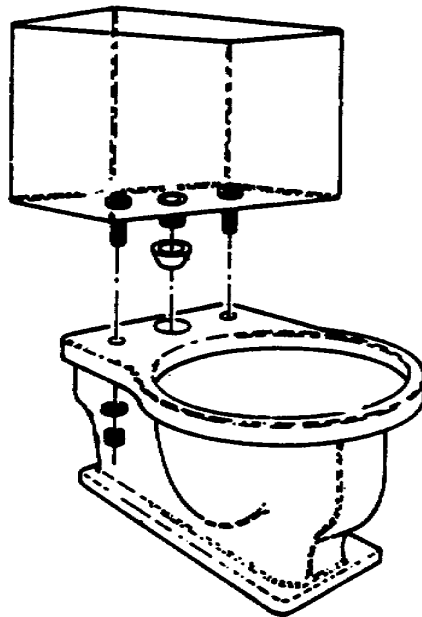

Solutions for this exercise are on page 71

**Lesson 2/Review Exercise**

7. Identify the two types of flushing mechanisms.

A. \_\_\_\_\_

B. \_\_\_\_\_

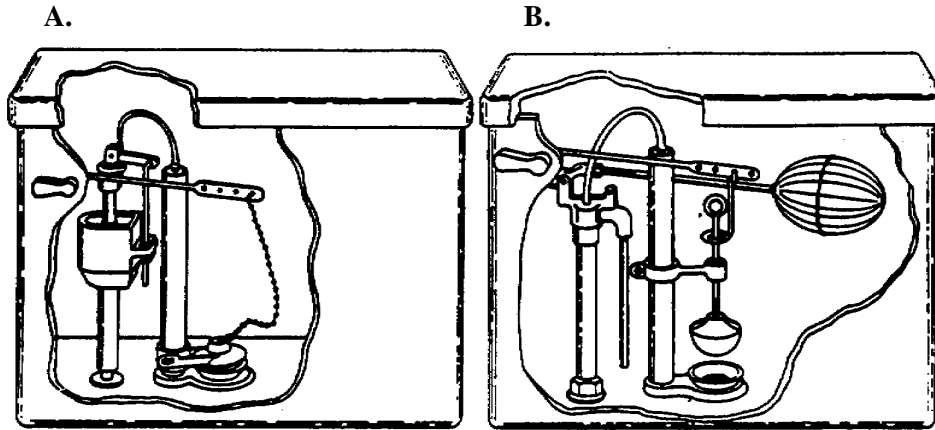

8. Using the letters A through J, list the steps in the correct order to install a ball cock type flushing mechanism in a flush tank.

- A. Screw float rod into ball cock, and then screw ball float to other end of rod.
- B. Attach overflow tube to ball cock and to overflow pipe.
- C. Install operating handle with trip arm, and tighten handle's locknut.
- D. Slide lift wire through loop of connecting wire.
- E. Slide the wire through guide holder, and screw flush ball onto threaded end of lift wire.
- F. Install ball cock assembly into hole at left bottom of tank, and then tighten locknut under tank.
- G. Slide guide holder onto overflow pipe about halfway down, and tighten holder screw.
- H. Connect Douglas valve to tank's drain outlet.
- I. Attach connecting wire to trip arm.
- J. Screw overflow pipe onto Douglas valve if not attached.

\_\_\_\_\_

\_\_\_\_\_

\_\_\_\_\_

\_\_\_\_\_

\_\_\_\_\_

\_\_\_\_\_

\_\_\_\_\_

\_\_\_\_\_

Solutions for this exercise are on page 71.

9. Identify the two types of flushometer valves.

- A. \_\_\_\_\_
- B. \_\_\_\_\_

A.

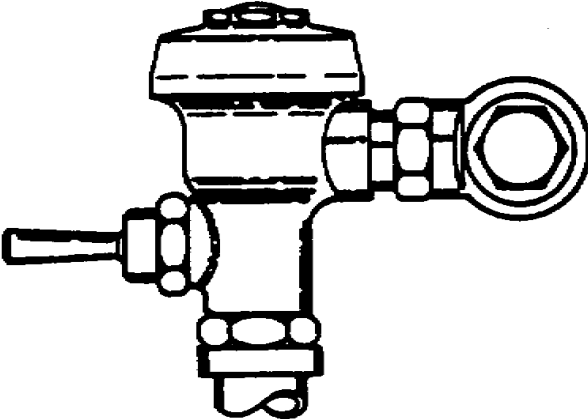

B.

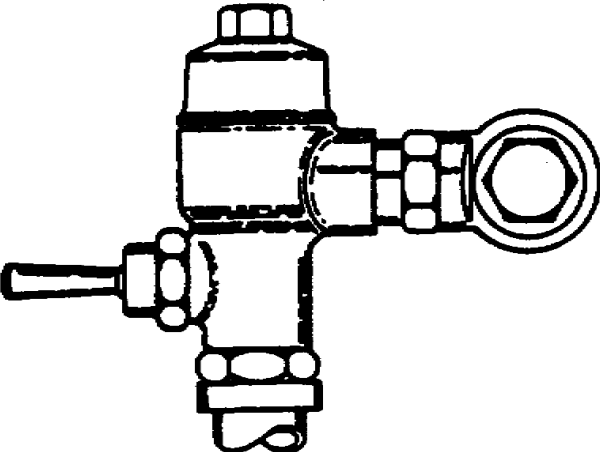

10. A flushometer valve is installed using the \_\_\_\_\_ instructions.

Solutions for this exercise are on page 71.

**Lesson 2/Review Exercise**

11. Using the letters A through G, list the steps in the correct order to install water supply service to a flush tank.

- A. Attach coupling nut to shutoff valve and tighten.
- B. Attach coupling nut to tank inlet and tighten.
- C. Set shutoff valve in close position.
- D. Attach shutoff angle valve, making the proper connection for the of pipe used. Make sure connection is tight and valve's other opening points straight up to tank.
- E. With a spring bender, bend flexible to connector to a fitting position.
- F. Side escutcheon on pipe, and push it against the wall.
- G. Slide tank connection coupling nut, valve connection coupling nut, and compression ring, in that order, onto the flexible tube connector.

---



---



---



---



---



---

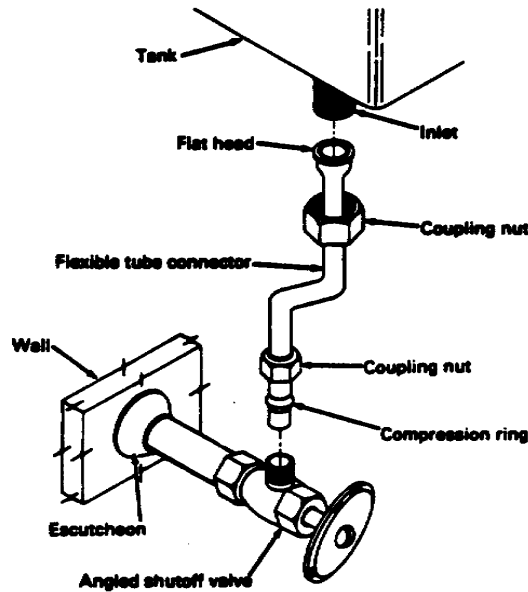

12. The water level in a flush tank should be about \_\_\_\_\_ below the top of the overflow pipe.

Solutions for this exercise are on page 71.

## REVIEW EXERCISE SOLUTIONS

1. A. Close-coupled (Page 38)  
B. Wall-hung
2. C (Page 40)
3. Horn (Page 41)
4. Base (Page 41)
5. Level (Page 42)
6. D (Page 45)  
E  
C  
A  
B
7. A. float cup (Page 50)  
B. Ball cock
8. H (Pages 50-51)  
J  
G  
F  
A  
B  
C  
D  
E  
I
9. A. Diaphragm (Page 56)  
B. Piston
10. Manufacturer's (Page 57)
11. F (Page 59)  
D  
E  
G  
A  
B  
C
12. 1 inch (page 61)

**Lesson 3**  
**INSTALLATION OF URINALS**

**OBJECTIVE**

At the end of this lesson you will be able to describe the procedures to install urinals.

**TASK**

Task No. 051-248-1010, Install urinals.

**CONDITIONS**

Given subcourse booklet number EN5113 and an examination response sheet. You will work at your own pace and in your own selected environment with no supervision.

**STANDARDS**

Within approximately 4 hours, you should be able to study the lesson resources, answer the review exercises, and select the correct response for each examination question. You must respond correctly to 80% of the examination questions in order to receive credit for this subcourse.

**CREDIT HOURS**

4

**REFERENCES**

FM 5-51K  
TM 5-551K

Lesson 3  
INSTALLATION OF URINALS

Learning Event 1:  
IDENTIFYING URINALS

A urinal is a fixture flushed with water whose liquid waste drains into the building's waste system. Urinals come in many shapes and sizes that are wall or floor-mounted. They are made of vitreous china or enameled cast iron. The flushing mechanism for most urinals is a flushometer-type valve. Four types of urinals are illustrated below (see Figure 35).

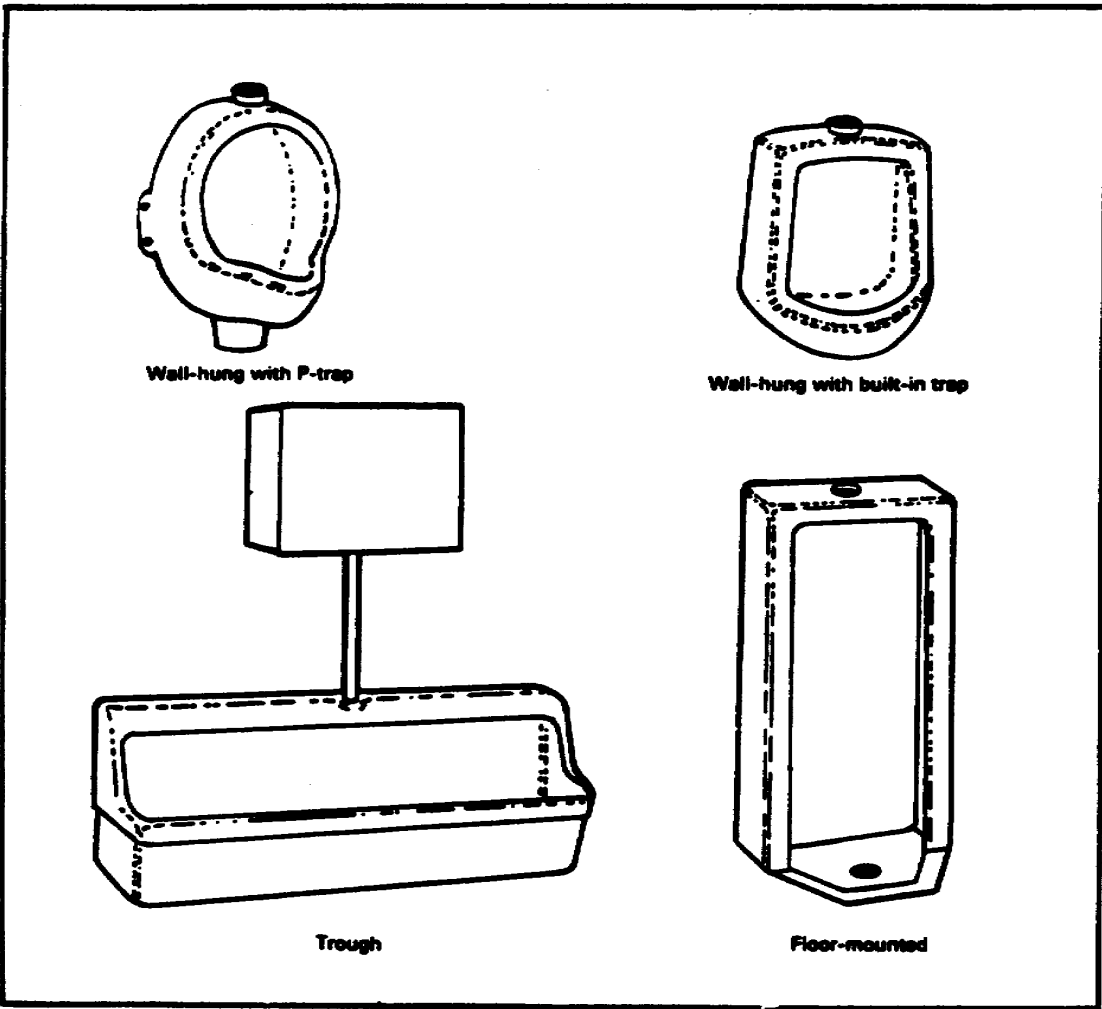

FIGURE 36. URINALS

*Types of flushometers for urinals.* The diaphragm type flushometer valve is mainly used to flush urinals. A piston type flushometer can also be used (see Figure 36).

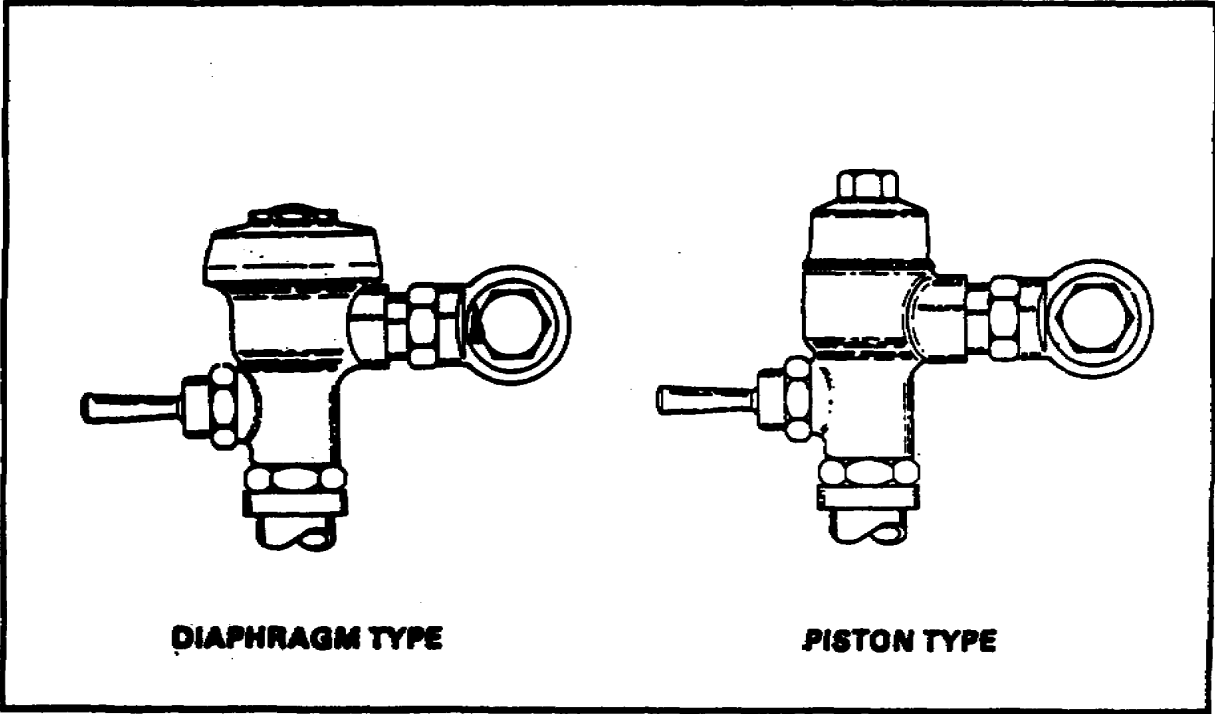
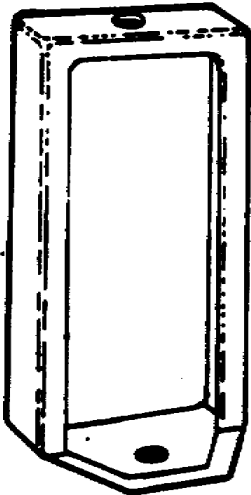

FIGURE 36. FLUSHOMETERS



**Learning Event 1**  
**SELF-CHECK EXERCISE**

1. Identify each type of urinal.  
A. \_\_\_\_\_  
B. \_\_\_\_\_  
C. \_\_\_\_\_  
D. \_\_\_\_\_



**A.**

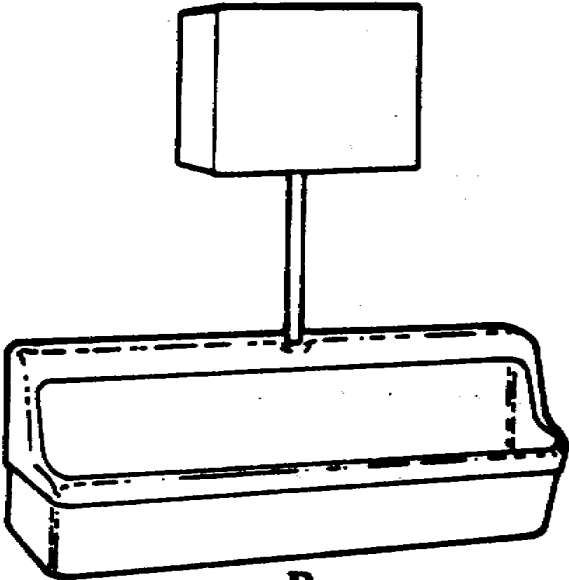

**B.**

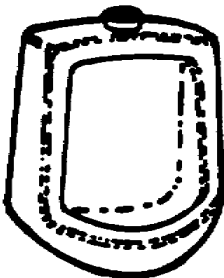

**C.**

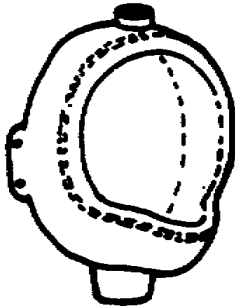

**D.**

Solutions for this exercise are on page 76.

2. Which flushometer valve, A or B, is mainly used to flush urinals?

\_\_\_\_\_

A.

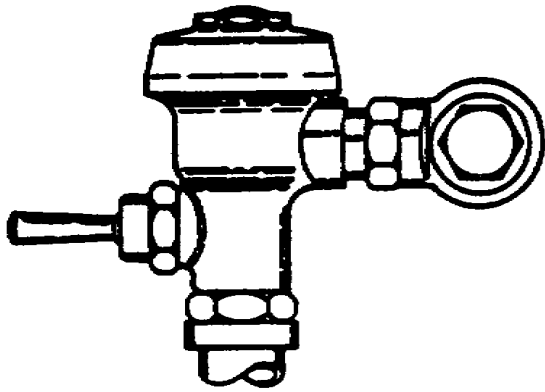

B.

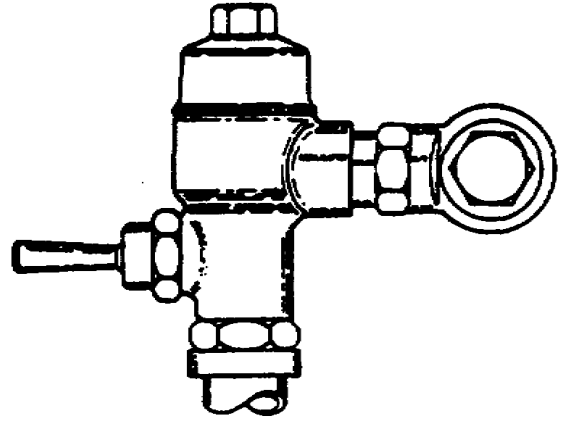

**SELF-CHECK EXERCISE SOLUTIONS**

1. A. Floor-mounted  
B. Trough  
C. Wall-hung  
D. Wall-hung with P-trap
2. A

**Learning Event 2:  
INSTALLING WALL-HUNG URINALS**

To install a wall-hung urinal, you need a mounting board to place between the wall studs for support and the manufacturer's rough-in specifications for the urinal. The rough-in specifications determine the height from the floor to install the mounting board between the studs. The mounting board is installed before the studs are covered with a finished wall (see Figure 37).

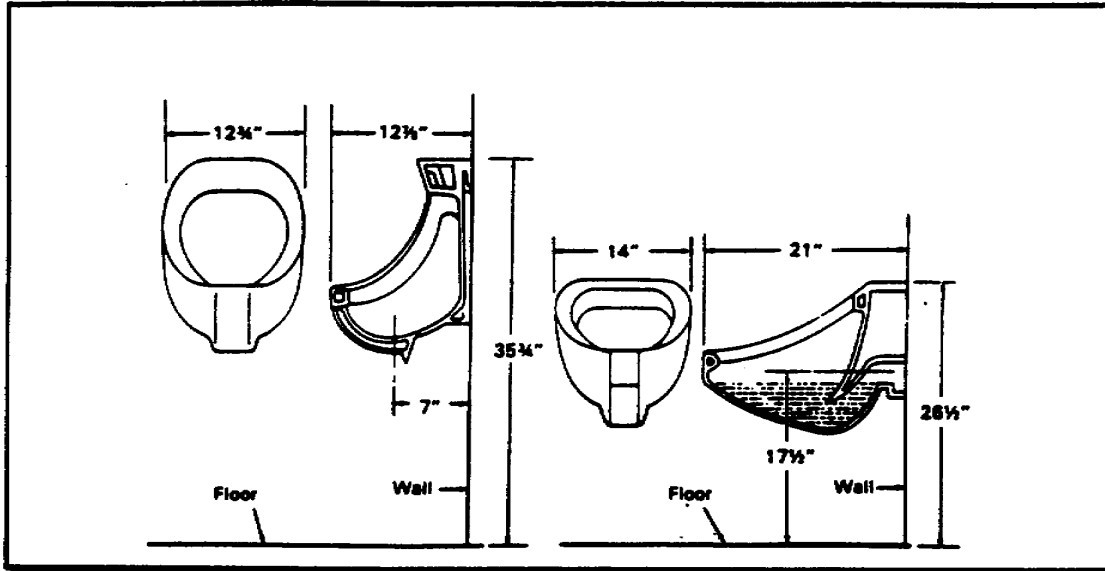

**FIGURE 37. MANUFACTURER'S SPECIFICATIONS**

A wall-hung urinal is fastened with screws or bolts to a mounting board behind the finished wall. Make sure the urinal is set in a level position (see Figure 38).

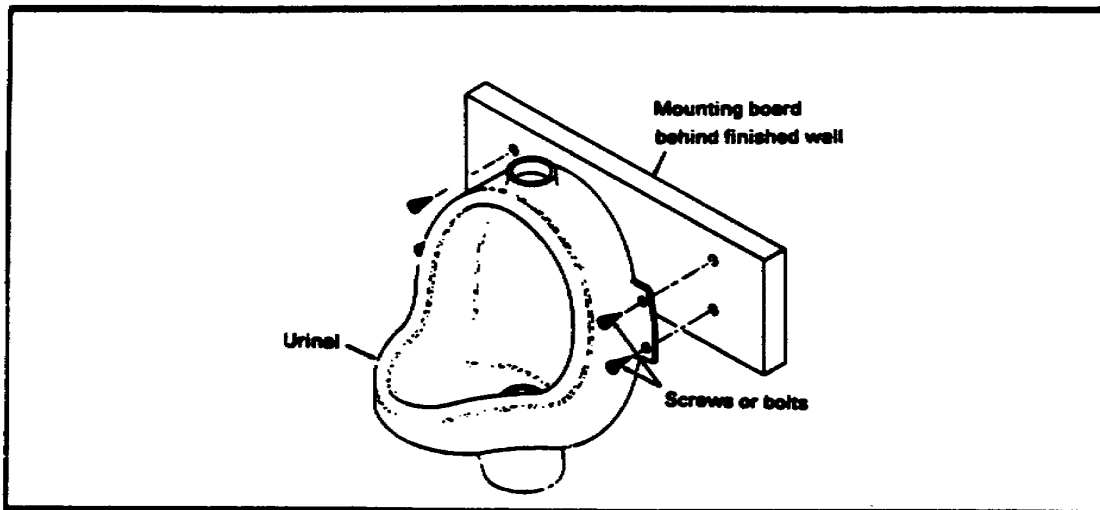

**FIGURE 38. ATTACHING WALL-HUNG URINAL TO WALL**

## Lesson 3/Learning Event 2

### Learning Event 2 SELF-CHECK EXERCISE

Fill in the blanks.

1. Installing a wall-hung urinal requires a \_\_\_\_\_ and the \_\_\_\_\_ rough-in specifications.
2. The height from the top of the urinal to the floor is given in the \_\_\_\_\_ rough-in specifications.
3. The urinal must be \_\_\_\_\_ when installed.

### SELF-CHECK EXERCISE SOLUTIONS

1. Mounting board, manufacturer's
2. Manufacturer's
3. Level

**Learning Event 3:  
ATTACHING DRAIN OUTLETS**

The drain outlet attachment for the urinal is the first step to install the urinal's drain attachment. The assembled parts of the drain outlet form the drain outlet attachment. Use the following steps to install the urinal's drain attachment (see Figure 39):

Place threaded spud housing, threads down, into urinal's drain outlet.

Slide rubber gasket onto spud housing through the drain outlet.

Slide metal washer onto spud housing.

Screw locknut onto spud housing, and tighten with a wrench.

Slide rubber washer, and then slip nut onto tailpiece.

Place tailpiece against spud housing, and screw slip nut hand-tight onto spud housing.

Tighten slip nut with a wrench.

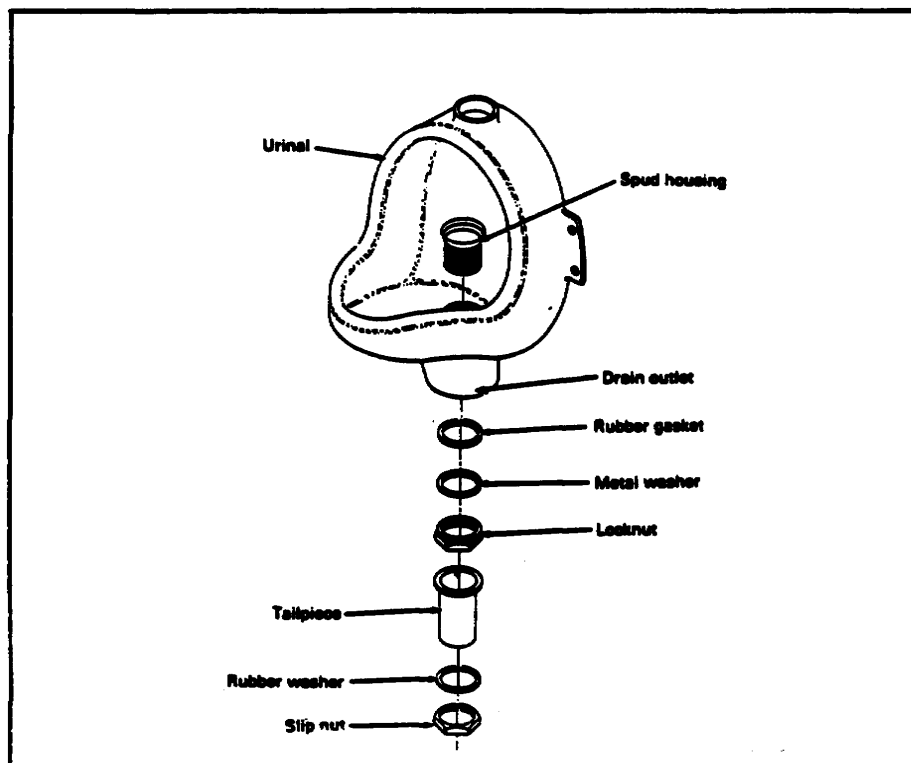

**FIGURE 39. INSTALLING URINAL DRAIN OUTLET**

**Lesson 3/Learning Event 3**

**SELF-CHECK EXERCISE**

Using the letters A through G, list the steps in the correct order to install the urinal's drain outlet attachment.

- A. Screw locknut onto spud housing, and tighten with a wrench.
- B. Slide rubber washer, and then slip nut onto tailpiece.
- C. Place tail piece against spud housing, and screw slip nut hand-tight onto spud housing.
- D. Tighten slip nut with a wrench.
- E. Place threaded spud housing, threads down, into urinal's drain outlet.
- F. Slide rubber gasket onto spud housing through the drain outlet.
- G. Slide metal washer onto spud housing.

---

---

---

---

---

---

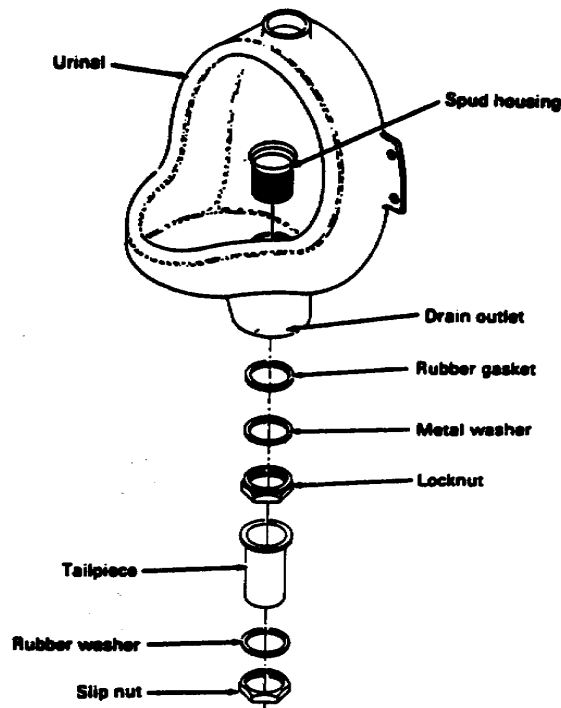

**SELF-CHECK EXERCISE SOLUTIONS**

E, F, G, A, B, C, D

**Learning Event 4:****CONNECTING P-TRAPS TO URINALS**

A urinal's waste connection is from the tailpiece to the rough-in plumbing. The connection is made by using a U-shaped trap, a drainpipe with a curved end, rubber washers, and slip nuts. Use the following steps to connect the urinal's P-trap (see Figure 40):

Slide escutcheon, slip nut, and rubber washer over the straight end of the drainpipe.

Slide straight end of drainpipe into rough-in plumbing.

Fasten slip nut hand-tight to rough-in plumbing.

Slide slip nut and then rubber washers over curved end of drainpipe and tailpiece.

Slide trap's lowest end onto drainpipe and highest end onto tailpiece.

Fasten slip nuts hand-tight on trap.

Line up the connections, and tighten all slip nuts.

Slide escutcheon against the wall.

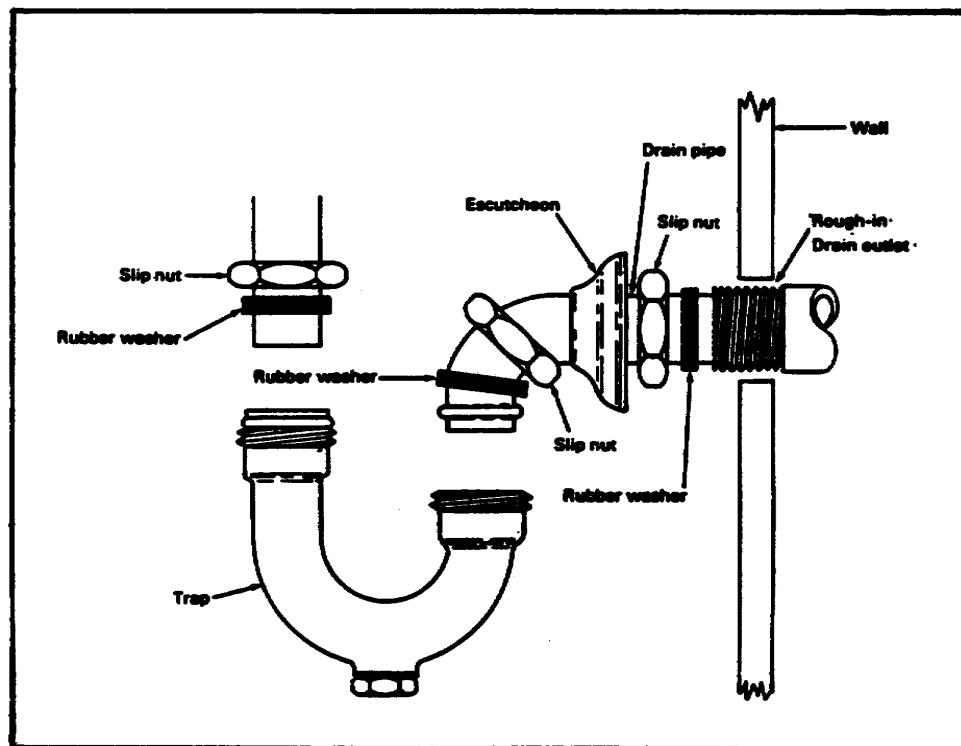

**FIGURE 40. CONNECTING P-TRAP TO URINAL**

**Lesson 3/Learning Event 4**

**SELF-CHECK EXERCISE**

Using the letters A through H, list the steps in the correct order to install a P-trap to the urinal.

- A. Slide trap's lowest end onto drainpipe and highest end onto tailpipe.
- B. Fasten slip nuts hand-tight on trap.
- C. Slide escutcheon, slip nut, and rubber washer over the straight end of the drainpipe.
- D. Slide straight end of drainpipe into rough-in plumbing.
- E. Line up the connections, and tighten all slip nuts.
- F. Slide escutcheon against the wall.
- G. Fasten slip nut hand-tight onto rough-in plumbing.
- H. Slide slip nuts and then rubber washers over curved end of drainpipe and tailpiece.

---

---

---

---

---

---

---

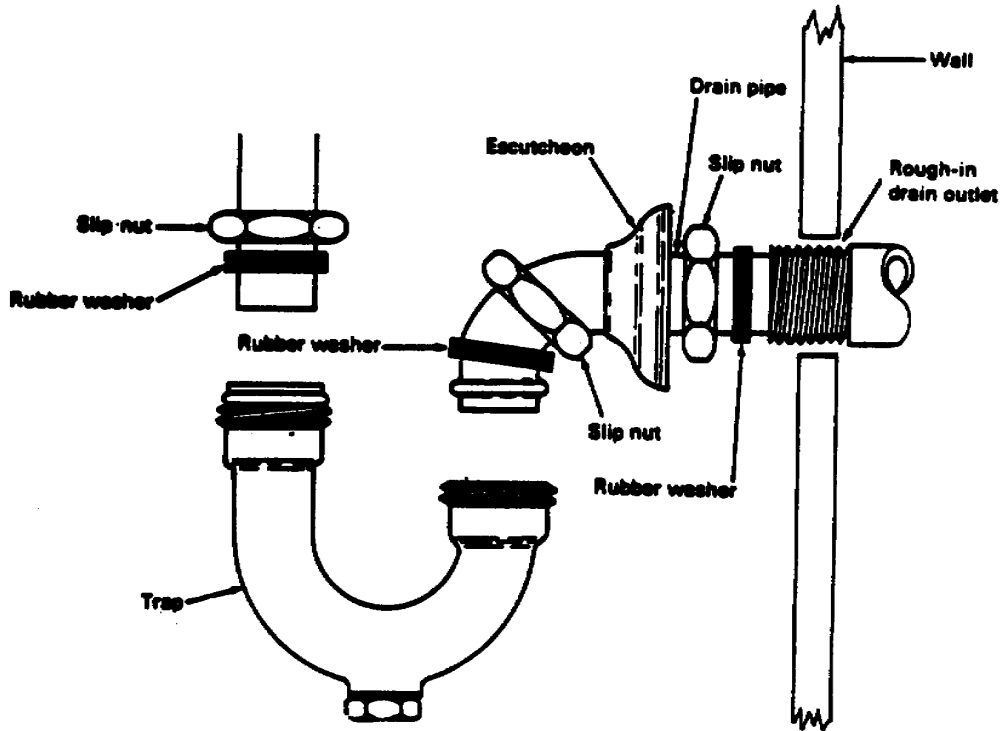



**SELF-CHECK EXERCISE SOLUTIONS**

C  
D  
G  
H  
A  
B  
E  
F

## Lesson 3/Learning Event 5

### Learning Event 5: INSTALLING FLUSHOMETERS

Cold water service for flushing a urinal is made with a flushometer. The flushometer is attached to a cold water supply line and then connected to the top of the urinal by assembling a group of plumbing parts.

**Installing urinal's water inlet connection.** Use the following steps to install the urinal's water inlet connection (see Figure 41):

Slide spud housing with threads up into water inlet hole.

Slide rubber gasket and metal washer onto spud housing, pushing the beveled end into the water inlet hole.

Screw locknut onto spud housing, and tighten nut.

Slide cover over threads of spud housing.

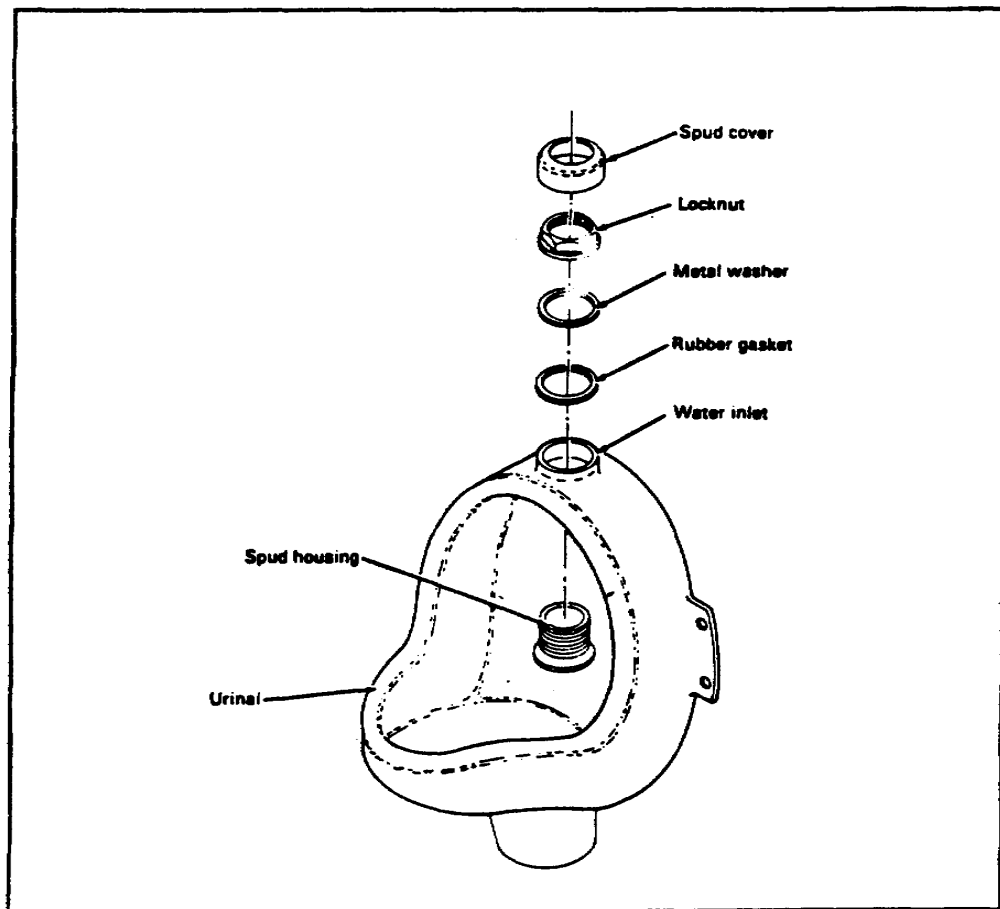

FIGURE 41. INSTALLING WATER INLET CONNECTION TO URINAL BOWL

***Installing the flushometer for water service.*** Use the following steps to install the flushometer for water service (see Figure 42):

Slide a rubber washer and then a slip nut with threaded end up to the top of the extension tube.

Slide a slip nut with threaded end down and then a rubber washer onto the extension tube.

Set bottom of extension tube onto spud, and fasten slip nut hand-tight to spud.

Set lower end of flushometer on top of extension tube, and fasten slip nut hand-tight onto flushometer.

Fasten flushometer's slip nut to rough-in water supply line connection at wall.

Tighten all slip nuts with a wrench.

Turn on water supply, and flush urinal several times to check for leaks and flushometer operation flow rate.

If flushometer requires adjustment, follow manufacturer's instructions.

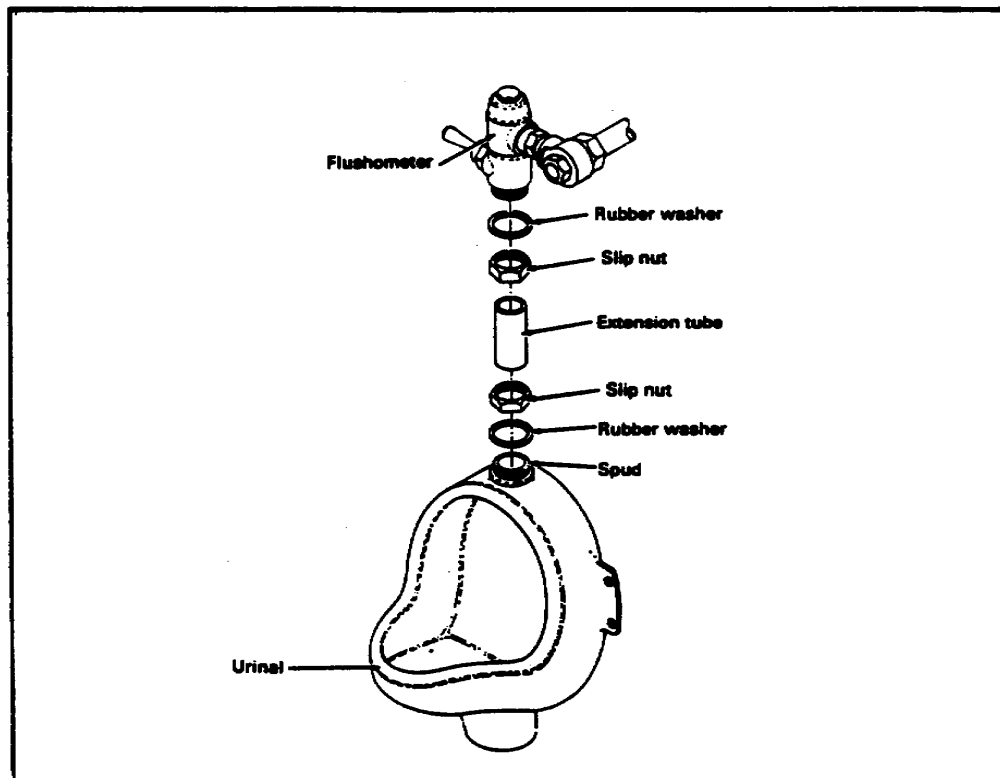

**FIGURE 42. INSTALLING WATER SERVICE**

## Lesson 3/Learning Event 5

### Learning Event 5 SELF-CHECK EXERCISE

1. Using the letters A through D, list the steps in the correct order to install a urinal's water inlet connection.

- A. Slide cover over threads of spud housing.
- B. Screw locknut onto spud housing, and tighten nut.
- C. Slide spud housing with threads up into water inlet hole.
- D. Slide rubber gasket onto spud housing, pushing the beveled end into the water inlet hole.

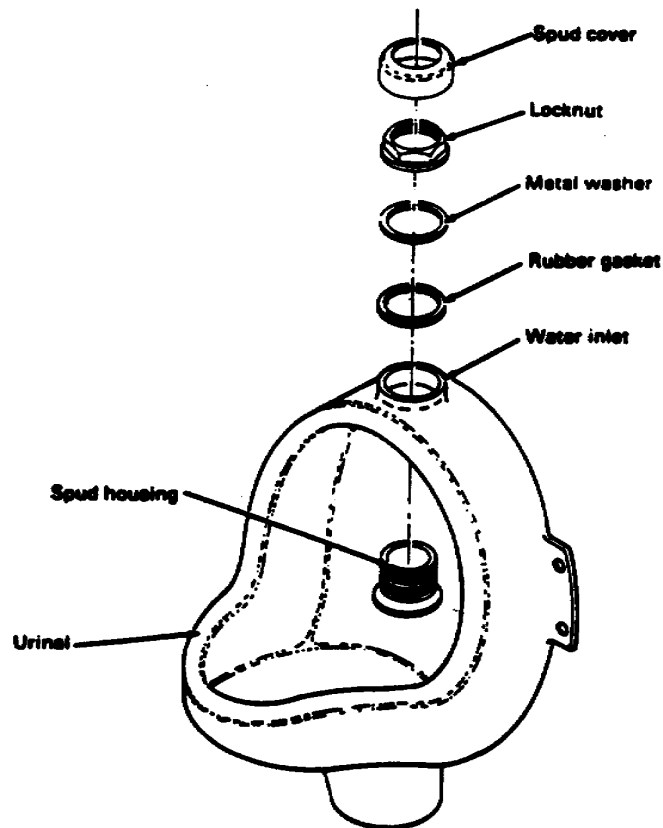

### SELF-CHECK EXERCISE SOLUTIONS

1. C  
D  
B  
A

2. Using the letters A through H, list the steps in the correct order to install a flushometer for water service.

- A. Slide a slip nut with threaded end down and then a rubber washer onto the extension tube.
- B. Fasten flushometer's slip nut to rough-in water supply line connection at wall.
- C. Set bottom of extension tube onto spud, and fasten slip nut hand-tight to spud.
- D. Set lower end of flushometer on top of extension tube, and fasten slip nut hand-tight onto flushometer.
- E. Tighten all slip nuts with a wrench.
- F. Slide a rubber washer and then a slip nut with threaded end up to the top of the extension tube.
- G. Turn on water supply, and flush urinal several times to check for leaks and flushometer operation flow rate.
- H. If flushometer requires adjustment, follow manufacturer's instructions.

\_\_\_\_\_

\_\_\_\_\_

\_\_\_\_\_

\_\_\_\_\_

\_\_\_\_\_

\_\_\_\_\_

\_\_\_\_\_

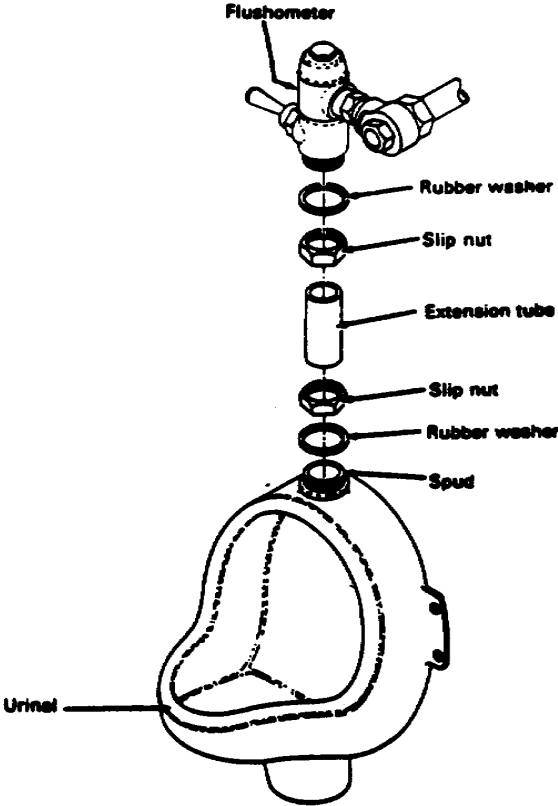

**SELF-CHECK EXERCISE SOLUTIONS**

2. F            B  
 A            E  
 C            G  
 D            H

**Lesson 3/Review Exercise**

**Lesson 3  
REVIEW EXERCISE**

Check your understanding of Lesson 3 by completing this review exercise. Try to complete all of the questions without looking back at the lesson. When you are finished, turn to the solutions at the end of the lesson and check your responses. If you missed any, go back and restudy the place in the lesson where the information is given.

1. List, in any order, three basic types of urinals.
  - A. \_\_\_\_\_
  - B. \_\_\_\_\_
  - C. \_\_\_\_\_
  
2. Wall-hung urinals are installed using the \_\_\_\_\_ rough-in specifications.
  
3. Using the letters A through G, list the steps in the correct order to install the drain outlet attachment.
  - A. Slide rubber washer and then slip nut onto tailpiece.
  
  - B. Place tailpiece against spud housing, and screw slip nut hand-tight onto spud housing. \_\_\_\_\_  
\_\_\_\_\_  
\_\_\_\_\_
  
  - C. Tighten slip nut with a wrench. \_\_\_\_\_  
\_\_\_\_\_
  
  - D. Slide metal washer onto spud housing. \_\_\_\_\_  
\_\_\_\_\_
  
  - E. Screw locknut onto spud housing, and tighten with a wrench.
  
  - F. Place threaded spud housing, threads down, into urinal's drain outlet.
  
  - G. Slide rubber gasket onto spud housing through the drain outlet.

Solutions for this exercise are on page 90.

4. Using the letters A through H, list the steps in the correct order to install the P-trap.

A. Slide slip nuts and then rubber washers over curved end of drainpipe and tailpiece.

B. Slide trap's lowest end onto drainpipe and highest end onto tailpiece.

C. Fasten slip nuts hand-tight on trap.

D. Line up the connections, and tighten all slip nuts.

E. Slide escutcheon against the wall.

F. Slide escutcheon, slip nut, and rubber washer over the straight end of drainpipe.

G. Slide straight end of drainpipe into rough-in plumbing.

H. Fasten slip nut hand-tight onto rough-in plumbing.

---

---

---

---

---

---

---

5. Using the letters A through D, list the steps in correct order to install the water inlet connection.

A. Slide cover over threads of spud housing.

B. Screw locknut onto spud housing, and tighten nut.

C. Slide rubber gasket onto spud housing, pushing the beveled end into the water inlet hole.

D. Slide spud housing with threads up into water inlet hole.

---

---

---

---

Solutions for this exercise are on page 90.

**Lesson 3/Review Exercise**

6. Using the letters A through H, list the steps in the correct order to install a flushometer for water service.

A. Set bottom of extension tube onto spud, and fasten slip nut hand-tight to spud.

B. Set lower end of flushometer on top of extension tube, and fasten slip nut hand-tight onto flushometer.

C. Fasten flushometer's slip nut to rough-in water supply line connection at wall.

D. Tighten all slip nuts with a wrench.

E. Slide a rubber washer and then a slip nut with threaded end up to the top of the extension tube.

F. Turn on water supply, and flush urinal several times to check for leaks.

G. If flushometer requires adjustment, follow manufacturer's instructions.

H. Slide a slip nut with threaded end down and then a rubber washer onto the extension tube.

---



---



---



---



---



---

**REVIEW EXERCISE SOLUTIONS**

1. A Wall-hung (Page 73)

B Floor-mounted

C Trough

2. Manufacturer's (Page 77)

3. F (Page 79)

G

D

E

A

B

C

4. F (Page 81)

G

H

A

B

C

D

E

5. D (Page 84)

C

B

A

6. E (Page 85)

H

A

B

C

D

F

G